



# Environmental Engineering Technology | 2016-2017 Assessment Report

1. Please give a brief overview of the assessment data you collected this year.
2. How will you use what you've learned from the data that was collected?

Assessment and how we will use what was learned (continuous improvement) are presented for each Fall 2016 course below.

## Course: ET 101 – Fundamentals of Engineering Technology (Fall 2016)

### Outcomes assessed: i

**Outcome (i):** An understanding of and commitment to address professional and ethical responsibilities including a respect for diversity.

**Assessment Question:** The outcome (i) was met by the following two questions in the course final exam:

1. Write a report on an engineering disaster which involved a failure in engineering ethics. [25 points]
  - a) The report should be minimum one-page length (not counting the header/title information and pictures).
  - b) The report should have a title (cover) page.
  - c) The report should have a reference page.
  - d) Breakdown the report content into multiple paragraphs (and bulleted points).
  - e) Clearly explain what aspect of engineering (mechanical, electrical, environmental, structural, electronics, communication, ...) failed during the disaster.
  - f) Clearly explain failure of which engineering ethics helped in the engineering disaster happening.
  - g) The report need not have an abstract, table of contents, results, conclusion, and acknowledgement sections.
  - h) Make sure to show at least one picture in your report relating to the disaster. The pictures do not count towards the minimum one-page length of the report.
  - i) The report (excluding the title page and reference page) should follow the following format; times new roman, 12 point, line spacing 1.
  - j) The title page and reference page format is up to you. Try to keep it professional.
  - k) Label the electronic copy of this report as *firstname\_lastname\_Q1\_Final\_ET101*.
  - l) Upload this electronic report as an individual submission in D2L in the Final Exam dropbox.

2. Write a report on a famous minority engineer, scientist, inventor or technologist. [25 points]

- a) The report should be minimum one-page length (not counting the header/title information and pictures).
- b) The report should have a title (cover) page.
- c) The report should have a reference page.
- d) Breakdown the report content into multiple paragraphs (and bulleted points, if needed).
- e) Make sure the following are addressed in the report regarding the chosen minority individual:
  1. Background; born, parents, class (poor, rich, middle-class, blue-collar, ...).
  2. Education
  3. Work experience
  4. Achievements
  5. Life after retirement (if applicable)
  6. Problems (either professional or personal) overcome during lifetime (if applicable)
- f) The report should have a profile picture of the chosen minority individual. Pictures do not count towards the minimum one-page length of the report.
- g) The report need not have an abstract, table of contents, results, conclusion, and acknowledgement sections.
- h) The report (excluding the title page and reference page) should follow the following format; times new roman, 12 point, line spacing 1.
- i) The title page and reference page format is up to you. Try to keep it professional.
- j) Label the electronic copy of this report as *firstname\_lastname\_Q2\_Final\_ET101*.
- k) Upload this electronic report as an individual submission in D2L in the Final Exam dropbox.

**Assessment Rubric:**

A) Assessment for question (1) relating to professional and ethical responsibility was performed using the rubric shown below. In each category the percentage and number of students (listed in parenthesis) achieving each criteria is reported.

N = 39 students	Unsatisfactory	Developing	Satisfactory	Exemplary
<b>Topic is thoroughly researched and properly cited</b>	No research done and/or citations absent	Research done with only "Wikipedia" or similar online webpage cited	Research done with non-wikipedia citation	Research done with multiple citations (at least 3)
	23.1% (9)	12.8% (5)	35.9% (14)	28.2% (11)

<b>Engineering disaster</b>	The location, people/company involved, date and impact on life not detailed  20.5% (8)	People/company involved & impact on life not detailed  2.6% (1)	Impact to life not detailed  7.7% (3)	The location, people/company involved, date and impact on life detailed  69.2% (27)
<b>Engineering disaster picture</b>	No picture  23.1% (9)	Picture presented without any citation and explanation  20.5% (8)	Picture presented with explanation but without any citation  25.6% (10)	Picture shown with citation and explanation  30.8% (12)
<b>Engineering failure</b>	Not explained  17.9% (7)	Mentioned without any explanation  2.6% (1)	Mentioned with simple explanation  17.9% (7)	Clearly explained  61.5% (24)
<b>Ethics failure</b>	Not mentioned  25.6% (10)	Mentioned without any explanation  10.3% (4)	Mentioned with simple explanation  15.4% (6)	Clearly explained  48.7% (19)

B) Assessment for question (2) relating to diversity was performed using the rubric shown below. In each category the percentage and number of students (listed in parenthesis) achieving each criteria is reported.

<b>N = 39 students</b>	<b>Unsatisfactory</b>	<b>Developing</b>	<b>Satisfactory</b>	<b>Exemplary</b>
<b>Topic is thoroughly researched and properly cited</b>	No research done and/or citations absent  23.1% (9)	Research done with only "Wikipedia" or similar online webpage cited  23.1% (9)	Research done with non-wikipedia citation  33.3% (13)	Research done with multiple citations  20.5% (8)
<b>Background of the minority individual</b>	Not listed  23.1% (9)	Just mentions the educational background  12.8% (5)	Mentions the educational background and upbringing  15.4% (6)	Mentions educational background, parents history and upbringing  48.7% (19)

<b>Achievement(s) of the minority individual</b>	Not mentioned  20.5% (8)	Mentions work experience (as achievements)	Highlights achievement(s)  17.9% (7)	Clearly explains the achievement(s)  61.5% (24)
<b>Issues (diversity or gender) faced by the individual</b>	Not mentioned  33.3% (13)	Picked an individual without any major issues  30.8% (12)	Mentioned without any explanation  20.5% (8)	Clearly explained  15.4% (6)
<b>Minority individual picture</b>	No picture  25.6% (10)	Picture presented without any citation and explanation  33.3% (13)	Picture presented with explanation but without any citation  33.3% (13)	Picture shown with citation and explanation  7.7% (3)

#### Continuous Improvement & Comments:

- The unsatisfactory data is a bit skewed as it includes four students who withdrew from class before the end of the semester.
- The questions used to assess these outcomes were from the final exam. Some students neglected these questions because they already knew the grades from these questions might not change their course letter grade. Will look to have these questions during the mid-term exam rather than the final exam next time these outcomes are assessed for this course.
- Next time this course is taught, more emphasis will be given to report writing format and citations.
- The students did not know about the above shown assessment rubrics. For future semesters, the rubrics will be made available to the students along with the questions. This will clearly help the students in better understanding what is required from the reports, which will result in majority students in the satisfactory and exemplary category.
- For some of the major items (ethics failure, engineering failure, achievements and background of minority person) in the above two rubrics, majority of the students either fall in the satisfactory or exemplary category.

#### Course: ET 105 Fundamentals of Drawing

##### Outcomes assessed: a

**Outcome a** states that a student will demonstrate: An ability to select and apply the knowledge, techniques, skills, and modern tools of the discipline to broadly defined engineering technology activities.

This was met with the following end of term assignment:

## Fundamentals of Drawing Final Project

### Objective

The overall final project objective is to demonstrate the knowledge gained regarding engineering drawing and graphics communication and the skills and techniques gained using AutoCAD from this course. Basically, the final project should bring together everything that you learned throughout the semester to address a broadly defined engineering technology problem.

### Project Description

For the final project, you should select an everyday object and come up with a novel design for improving the object. You will then step through the design process, as outlined below, with the final goal of providing a short report regarding your design and the final design drawings. You will also be required to submit deliverables at certain stages of the project to simulate the design process and to ensure you complete the project by the end of the semester. Overall, this is intended to be open ended. You can select any object that you are interested in improving. However, you should select an object that is appropriately complex. The object should not be any simpler than the objects we have been drawing in class, but the object should also not be overly complex to the point you can't complete it within the remainder of the semester. In addition, the focus of the project is to apply the knowledge and skills you learned in this class, which is focused on engineering drawing. Therefore, the design should at the minimum pass one criterion; does this have the potential to work (Note: this is not will it work)? Thus, use your developing engineering judgement, but do not focus your time on coming up with an optimal or even working design. Be creative and think outside of the box.

### Measurement Instruments

You have access to electronic and Vernier calipers and outside and inside micrometers for obtaining precise measurements of your object. We will go over how to use these in class, but you are welcome to check them out temporarily.

### Grading Rubric

The final project is a total of 250 points. A more detailed grading rubric is attached to this document.

### Deliverables

The project will be divided into four parts, which will help you step through the design process and make sure you complete the project before the end of the semester. Associated with these four parts, will be four deliverables, which you will have to provide to me by their respective due dates/deadlines. The deadlines and deliverables are a simplified version of what you will experience while working as an engineer.

#### Deliverable 1 (Due 11/5/16) – Project Proposal

For Deliverable 1, provide a technical memorandum (maximum of 2 pages) outlining the following information:

1. Create an engineering company and describe the type of work the company focuses on (e.g., electrical, environmental, mechanical engineering design, etc.). Your company should also have a logo.
2. State that your company has been hired to complete your proposed improvement of your selected object for your client.
3. Describe your proposed improvement and why it is important in the context of the people that use/come in contact with the object and in a broader context, how it impacts the community, the engineering field, the world, etc.
4. Provide a picture and description of the object you intend to improve and be sure to reference the picture in your document.
5. An outline and description of the deliverables you will submit throughout the project.

### **Deliverable 2 (Due 11/12/16) – Technical sketch**

For Deliverable 2, provide a technical memorandum (maximum of 2 pages, not including your sketch) describing and including a technical sketch of your object with the proposed improvement. The technical sketch can be any view of your choosing, but should readily and accurately display the improvement you are making. The memorandum should include the following items under the appropriate headings:

- Brief introduction briefly summarizing the overall project and reminding the client of the purpose of the project.
- Describe the submittal and how it fits into the overall project outline.
- A more detailed description of your proposed improvement.
- Provide a technical sketch (attached to the document in an appendix) that you reference in the document.
  - Completed on engineering paper.
  - Provide basic dimensions for the client to be able to visualize the size of the object.
  - Provide notes on the sketch with further detail on how the object will be modified (i.e., changes in design, material, etc.)

### **Deliverable 3 (Due 12/1/16) – Preliminary Design**

For Deliverable 3, provide a technical memorandum (maximum of 2 pages, not including drawings) describing and including your preliminary design drawings. The memorandum should include the following items under the appropriate headings:

- Brief introduction briefly summarizing the overall project and reminding the client of the purpose of the project.
- Describe the submittal and how it fits into the overall project outline.
- A more detailed description of your proposed improvement, especially if you have made any modifications since Deliverable 2.
- Provide preliminary drawings of your object (attached to the document in an appendix) with the proposed improvements that you reference in the document. The drawings should include some dimensions and be placed in a complete titleblock. A description of what is expected for your final drawings is provided below.
  - Three standard orthographic views (front, top, and right side views)

## **Deliverable 4 (Due 12/8/16) – Final Design and Final Submittal**

For Deliverable 4, provide a final technical memorandum (maximum of 5 pages, not including your drawings) describing and including your final design drawings. The memorandum should include the following items under the appropriate headings:

- Introduction: Restate the introductory information provided in Deliverables 1-3, but explain that this is your final design. Include a picture and description of your original object.
- Proposed Solution: Describe your final proposed solution to improve the object. Describe any changes that were made from previous Deliverables. Again, state how this object impacts those that use/come in contact with the object and in a broader context, how it impacts the community, the engineering field, and the world, etc. The proposed solution section should also include a detailed description of the following:
  - The proposed improvement and reference all of your final drawings, which should be attached to the document in an appendix. A more detailed description of what is required for your final drawings is provided below.
  - A description of the material(s) that are recommended for the improvement. You will not be graded on choosing the 'correct' material, but you should provide a thoughtful analysis of what materials would likely be suitable.
  - Describe considerations that need to be accounted for in the manufacturing, marketing, and distribution of the improved product.
  - A description and discussion of any tolerances associated with the improved object. You are not required to provide tolerances in the drawing, but you should base this discussion on tolerances that may be needed for manufacturing the parts for your improvement.
- Conclusions: State your major conclusions of the proposed improvement. Discuss further work that should be completed to make sure your improvement is viable (i.e., life-cycle cost analysis, material testing, prototyping, etc.).

### **Final Drawings**

Your final drawings must include a titleblock with at least the name of your company (a logo is helpful here), drawing title, drawing number, scale, drawing size, sheet number, drafter name, and date. All the drawings should be fully dimensioned, so the improvement could be manufactured based on the drawings alone. The drawing should also include the correct linetypes and should be organized and not cluttered. Lastly, provide any notes on the drawing to describe anything that is not discernable from the drawings themselves (i.e., proposed material, proposed cuts, etc.)

### **Required Drawings**

- Three standard orthographic views (front, top, and right side views).
- At least two of the following:
  - Isometric/Oblique drawing.
  - Section view (i.e., full, half, broken out, revolved, removed, offset, aligned, or assembly).
  - A detail drawing of a particular area of the object (Note: this is more detailed than what is provided in your standard orthographic views).
  - Auxiliary view drawing.

## **Final Submittal**

The final design should be submitted in one binder along with the following:

- Brief 1 paragraph formal letter on company letterhead explaining to the client the purpose of the submittal and everything included in the final submittal.
- Table of contents outlining everything in the submittal
- Divider tabs should be provided to separate the following parts of the submittal.
  - Deliverable 1
  - Deliverable 2
  - Deliverable 3
  - Deliverable 4

**Assessment was performed using the rubric below, along with the Average grade for each category of the 11 students that completed the project.**



Project Component	Graded Component	Maximum Score						Minimal Requirements for Maximum Points	Average Grade (n=11)	
		Document	Technical Sketch	Front View	Top View	Right Side View	Additional Drawing 1			Additional Drawing 2
Deliverable 1 (15 points)	<b>Technical Memorandum</b>									
	Company description and logo	1						A description and a logo of the company are provided. The type of work the company completes is also explained.	0.83	
	Purpose of company retainment	1						Retainment of the company is clearly stated to improve an object.	0.92	
	Proposed improvement description	4						Proposed improvement is thoroughly described, has the potential to work, and is appropriately complex.	3.96	
	Impacts of proposed solution	1						How the e improvements to the object impact those that use or come into contact with the object are explained. Broader impacts on the community, the industry, and the world are also mentioned.	1.00	
	Picture and description of object	3						A picture of the original object is provided, as well as a description of the object.	2.83	
	Outline of deliverables	1						The memorandum states that four deliverables will be provided in completion of this project. A description, including deadlines is provided for each deliverable.	0.54	
	Succinct Technical Writing	3						The writing is free of punctuation and grammatical errors. The writing is also objective and not repetitive. The writing is clear and to the point.	2.38	
Format	1						Document is correctly formatted as a technical memorandum and includes section headings or figure/table captions	0.71		
Deliverable 2 (25 points)	<b>Technical Memorandum</b>								13.17	
	Brief introduction	2						A brief introduction summarizing the overall project and reminding the client of the purpose of the project	1.92	
	Submittal description and submittal outline	1						Description of Deliverable 2 and how it fits into the overall project outline.	0.54	
	More detailed description of proposed improvement	3						More detailed description of proposed improvements, including an modifications from Deliverable 1.	2.83	
	Reference technical sketch	1						The technical sketch is referenced in the document.	1.00	
	Succinct Technical Writing	3						The writing is free of punctuation and grammatical errors. The writing is also objective and not repetitive. The writing is clear and to the point.	2.29	
	<b>Technical Sketch</b>								2.00	
	Engineering paper		1					Technical sketch is completed on engineering paper. A name of sketch is provided.	1.00	
	Basic dimensions		3					Basic dimensions are provided for the client to be able to visualize the size of the object.	2.42	
	Notes		2					Appropriate notes are provided on the sketch for further detail regarding how the object will be modified (i.e., changes in design, material, etc.)	1.82	
	Neatness		4					The sketch is neat, organized, and free of eraser marks.	4.00	
	Representation of object		5					The object is sketched to proportion and is relatively accurate.	4.82	
Deliverable 3 (50 points)	<b>Technical Memorandum</b>								23.00	
	Brief introduction	2						A brief introduction summarizing the overall project and reminding the client of the purpose of the project	1.77	
	Submittal description and submittal outline	1						Description of Deliverable 3 and how it fits into the overall project outline.	0.64	
	More detailed description of proposed improvement (note any modifications to previous submittals)	3						More detailed description of proposed improvements, including an modifications from Deliverables 1 and 2.	2.64	
	Reference preliminary drawings	1						The preliminary drawings are referenced in the document.	0.55	
	Succinct Technical Writing	3						The writing is free of punctuation and grammatical errors. The writing is also objective and not repetitive. The writing is clear and to the point.	2.41	
	<b>Preliminary drawings</b>								#DIV/0!	
	Dimensions			3	3	3		The major dimensions are called out on the drawing.	7.86	
	Title block					3		The drawings are correctly placed on a title block.	3.00	
	<b>Three standard orthographic views</b>								#DIV/0!	
	Presence and representation of object			4	4	4		Preliminary drawings of the three standard orthographic views are provided and correctly show the object modified object.	11.27	
	Organization				4			The three standard views are not cluttered on the title block and are in the standard position.	4.00	
Linetypes			4	4	4		The correct linetypes are used to represent visible, hidden, and centerlines.	11.05		
Deliverable 4 /Final Submittal (160 points)	<b>Report</b>								45.18	
	<b>Introduction</b>									
	Company description and logo	2						A description and a logo of the company are provided. The type of work the company completes is also explained.	1.73	
	Purpose of company retainment	2						Retainment of the company is clearly stated to improve an object.	1.82	
	Introduction to problem	3						The problem the proposed improvement is attempting to fix should be clearly stated.	2.45	
	Picture and description of object	3						A picture of the original object is provided, as well as a description of the object.	2.32	
	<b>Proposed Solution</b>									
	Description of proposed solution	5						The final proposed improvement is thoroughly described, has the potential to work, and is appropriately complex. Any modifications from the previous Deliverables should be noted.	4.64	
	Impacts of proposed solution	5						How the e improvements to the object impact those that use or come into contact with the object are explained. Broader impacts on the community, the industry, and the world are also mentioned.	4.59	
	Reference drawings	2						The final drawings are referenced in the document.	1.05	
	Material description/discussion	5						A discussion is provided regarding the material(s) that are recommended for the improvement. The discussion should include consideration of the exiting object's material, as well as, how the modification is manufactured and distributed.	5.00	
	Manufacturing, marketing, and distribution considerations	5						A discussion is provided regarding considerations for manufacturing, marketing, and distribution of the object based on the design and recommended materials.	3.95	
	Description and discussion of tolerances	5						A discussion should be provided of any tolerances required for manufacturing the parts for the proposed improvement.	3.10	
	<b>Conclusions</b>								0.00	
	Major conclusions	5						The major conclusions of the proposed improvement are discussed.	1.95	
	Discussion of further work	5						Future work to ensure the viability of the proposed improvement should also be discussed. This discussion should include topics like life cycle cost analysis, material testing, prototyping, modeling, etc.	3.86	
	Succinct Technical Writing	3						The writing is free of punctuation and grammatical errors. The writing is also objective and not repetitive. The writing is clear and to the point.	2.32	
	<b>Final Drawings</b>									
	Title block				3		3	3	The drawings are correctly placed on a completed title block with at least the name of the company (a logo is helpful here), drawing title, drawing number, scale, drawing size, sheet number, drafter name, and date.	7.09
	Linetypes			5	5	5	5	5	The correct linetypes are used to represent visible, hidden, and centerlines. Other linetypes should also be used appropriately following the guidelines in class.	23.27
	Organization				5		5	5	The drawings are not cluttered on the title block and are in the standard position.	13.91
	Notes				2		2	2	Appropriate notes are provided on the drawings for further detail regarding how the object will be modified (i.e., changes in design, material, etc.)	3.41
	Dimensions			4	4	4	4	4	All dimensions are provided to completely manufacture the part.	15.59
	Neatness			5	5	5	5	5	The drawings are neat. There are no extra lines, text, etc. The dimensions do not obscure the drawing details	24.27
	<b>Final Submittal</b>									
	Binder	1							Deliverable 4 should be included with the graded and returned deliverables 1, 2, and 3 in a three ringed binder.	1.00
	Letter	2							A Brief 1 paragraph formal letter on company letterhead should be provided explaining to the client the purpose of the submittal and everything included in the submittal.	1.45
Table of contents	1							The final submittal should include a table of contents referencing the 4 deliverables.	0.75	
Divider tabs	1							Divider tabs should be used to separate the 4 deliverables.	0.55	
Deliverable 1	1							Include the graded and returned Deliverable 1.	0.91	
Deliverable 2	1							Include the graded and returned Deliverable 2.	0.91	
Deliverable 3	1							Include the graded and returned Deliverable 3.	0.91	
Deliverable 4	1							Include Deliverable 4.	1.00	
Professional appearance	2							The overall final submittal has a professional appearance.	1.91	
								<b>Average Total Score (out of 160)</b>	<b>135.36</b>	
								<b>Average Total Score (%)</b>	<b>0.85</b>	

**Continuous improvement:**

**ET105: Outcome a**

The project should be started earlier in the semester and include more time to improve the drawings and complete the final report. With more time, the students should also be required to complete additional drawings, along with a title page and legend page.

**Course: ET 206 Chemistry for Engineers (Fall 2016)**

Outcomes assessed: g

**Outcome g** states that a student will demonstrate: an ability to apply written, oral, and graphical communication in both technical and non-technical environments; and an ability to identify and use appropriate technical literature.

The following assignment was used to assess **outcome g**, and the assessment rubric is provided below with the percentage/number of students who achieved unsatisfactory, developing, satisfactory or exemplary for each item in the rubric.

The following chemistry laboratory exercises reports:

1. Stoichiometry of an acid-base reaction (focus on technical report format)
2. Qualitative analysis (focus on technical literature)
3. Kinetics: activation energy and catalysis (focus on data tabular and graphical presentation)
4. Molecular mass by vapor density (focus on technical report improvement)

Assessment was performed using the rubric below. In each category the percentage / number of students achieving each criteria is reported.

n= 9 students	Unsatisfactory	Developing	Satisfactory	Exemplary
<b>Stoichiometry of an acid-base reaction (technical report format)</b>	Receives less than 50 percentage of report grade 0, (0)	Receives more than 60 percentage of report grade 44.5%, (4)	Receives more than 80 percentage of report grade 22.2%, (2)	Receives more than 90 percentage of report grade 33.3%, (3)
<b>Qualitative analysis (technical literature)</b>	Receives less than 50 percentage of report grade 0, (0)	Receives more than 60 percentage of report grade 22.2%, (2)	Receives more than 80 percentage of report grade 44.5%, (4)	Receives more than 90 percentage of report grade 33.3%, (3)

<b>Kinetics: activation energy and catalysis (data tabular and graphical presentation)</b>	Receives less than 50 percentage of report grade 0, (0)	Receives more than 60 percentage of report grade 0, (0)	Receives more than 80 percentage of report grade 22.2%, (2)	Receives more than 90 percentage of report grade 77.8%, (7)
<b>Molecular mass by vapor density (technical report improvement)</b>	Receives less than 50 percentage of report grade 0, (0)	Receives more than 60 percentage of report grade 0, (0)	Receives more than 80 Percentage of report grade 22.2%, (2)	Receives more than 90 Percentage of report grade 77.8%, (7)

### Continuous improvement

#### ET206: Outcome g

This outcome has been achieved and no significant changes will need to be made.

### Course: ENGR 213 Engineering Mechanics I

#### Outcomes assessed: j

Outcome j: A knowledge of the impact of engineering technology solutions in a societal and global context.

The following assignment was used to assess outcome j and the assessment rubric is provided below with the percent and (number) of students who achieved unsatisfactory, developing, satisfactory, or exemplary for each item in the rubric.

Paper: Chose a modern engineering innovation and write a 8-10 page paper (double spaced, font size 11 or 12) answering the following

1. Describe the problem that the innovation was seeking to solve.
2. Investigate and describe what constituencies (people, the environment, companies, etc) benefitted from the innovation and how they benefitted. Consider this on a global scale.
3. Investigate and describe what constituencies were negatively impacted by the innovation and how they were impacted.
4. Describe relationships and potential outcomes between affected constituencies
5. Based on the above, assess the solution on a global scale

Assessment was performed using the rubric below. In each category the percentage and (number) of students achieving each criteria is reported.

n = 8 students	Unsatisfactory	Developing	Satisfactory	Exemplary
<b>Describes the project and its purpose</b>	Fails to define problem or describe its purpose  0, (0)	Gives little information about project and purpose  0, (0)	Adequately describes project and purpose from one perspective  0%, (0)	Thoroughly describes project and purpose from more than one perspective  100% (8)
<b>Investigates and discusses what entities will benefit and how</b>	Fails to describe what entities will benefit or how they will benefit  0, (0)	Identifies one benefit and which entity benefits  0, (0)	Identifies/discusses two to three benefits; local recipient entities; and the nature of the benefits  75%, (6)	Thoroughly assesses multiple benefits and recipients and the nature of the benefit both locally and globally  25%, (2)
<b>Investigates and discusses what entities will suffer and how</b>	Fails to describe what entities will suffer or how they will suffer  (0)	Identifies one negative outcome and the recipient entity  12.5%, (1)	Identifies/discusses two to three negative outcomes, local recipient entities; and the nature of the negative outcome  50%, (4)	Thoroughly assess multiple negative outcomes and recipients and the nature of the outcome locally and globally  37.5%, (3)
<b>Describes realistic potential outcomes between affected parties</b>	Fails to describe relationships or outcomes between affected groups  12.5%, (1)	Hypothesizes some outcomes, but fails to consider if they are realistic  12.5%, (1)	Identifies at least one potential realistic outcome in the context of relationships between entities  62.5%, (5)	Thoroughly discusses from more than one perspective realistic outcomes in the context of relationships between affected groups  12.5%, (1)
<b>Assess and discuss global precedents</b>	Makes no assessment  12.5% (1)	Makes some assessment but fails to consider global precedents  25%, (2)	Assesses based on one perspective and considers global precedents from this perspective  50%, (4)	Gives thorough assessment based on multiple perspectives and discusses global precedents from multiple perspectives  12.5%, (1)

<b>Paper is well organized with correct spelling and grammar</b>	Little organization and multiple grammar/spelling errors per page  12.5%, (1)	Paper has some inconsistent organization and 2 to 3 spelling/grammar errors per page  25%, (2)	Paper is organized with no more than 1 spelling/grammar error per page  37.5%, (3)	Paper is well organized and only 5 or fewer spelling/grammar errors in entire paper  25%, (2)
--	---	--	--	---

### Continuous improvement

#### ENGR 213: Outcome j

Engineering students often have difficulty with basic grammar and spelling as is evidenced by the summary assessment. This fall I allowed them to turn in a first draft for me to proofread before handing in the final paper, but only two students took advantage of this. Next fall, I will make this mandatory and average the grades from the first and revised papers to assign a final grade. We will also spend more time in class discussing the specifics of each criteria and examples will be provided to help students determine relationships and outcomes and future precedents.

ENGR 213 also meets the University requirement for a Writing Emphasis general education learning outcome. The above paper was also graded for writing emphasis using the rubric below.

**Assessment for the second criteria, writing emphasis, was performed using the rubric below. In each category the percentage and (number) of students achieving each criteria is reported.**

n = 8 students	Unsatisfactory	Developing	Satisfactory	Exemplary
<b>Topic is thoroughly researched and properly cited</b>	Topic is not researched much beyond given information	One or two appropriate references are used and cited	Three or four appropriate references are used and cited	Topic is thoroughly researched from multiple (5 or more) sources and is well cited  100%, (8)
<b>Paper is well organized</b>	Paper is not organized at all	Paper has some organization, but inconsistent  12.5%, (1)	Paper is organized according to the questions asked, but not well organized overall	Paper is organized according to topics and overall into an easy to follow flow of information  87.5%, (7)

<b>Correct grammar and spelling are used throughout</b>	Grammar and spelling are poor – many errors per page  25%, (2)	Grammar and spelling are marginally acceptable – 2 to 3 errors per page  12.5%, (1)	Grammar and spelling are good – no more than one error per page  25%, (2)	Grammar and spelling are near perfect – no more than 3 errors in entire paper  37.5%, (3)
<b>Tables and figures illustrate concepts</b>	No tables or figures are provided  37.5%, (3)	One figure or table is given – a map of area  12.5%, (1)	Tables and figures illustrate some concepts  12.5%, (1)	Tables and figures completely support the text  37.5%, (3)

**Continuous improvement**

As stated above, engineering students are often poor writers. Only two students took advantage of an early submission opportunity, so next fall, I will make this required and average the first draft and the revised draft grades. I will also emphasize using and referencing figures, etc..to illustrate the technology being assessed.

**Course: ET 308 – Finite Element Analysis**

**Outcome Assessed: the students will demonstrate outcome (b)**

**Outcome (b):** An ability to select and apply a knowledge of mathematics, science, engineering, and technology to engineer technology problems that require the application of principles and applied procedures or methodologies.

**Assessment Question:** The outcome (b) was met by the course final exam listed below:

The figure below shows the frame structure of a light cycle. A person is sitting on the light cycle and the load is assumed to be distributed as shown below. The light cycle is made up of aluminum 6061 alloy.

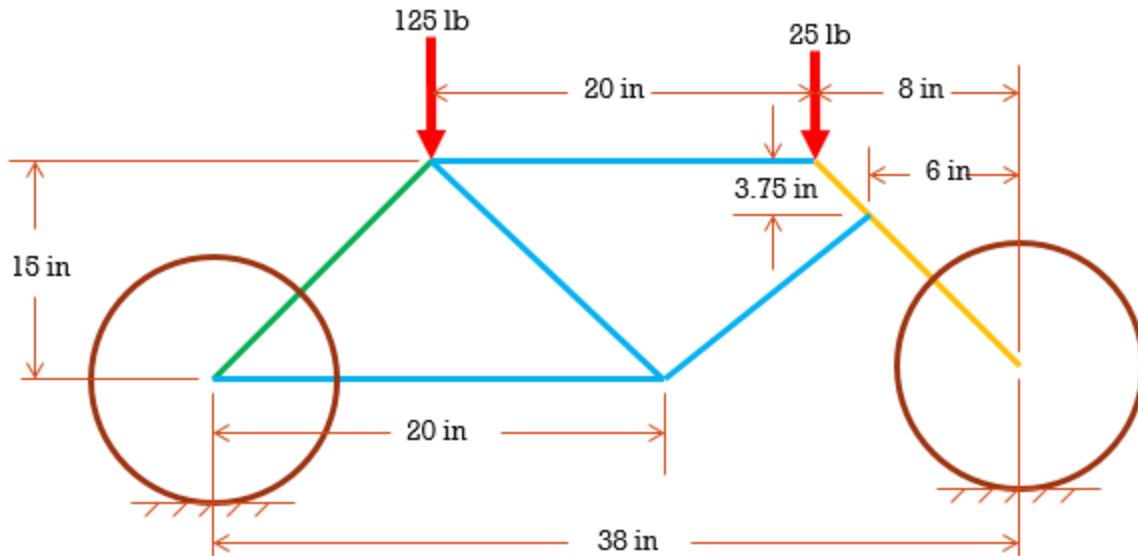

Assuming the frame structure comprises of beams, below are the cross-sections used for the light cycle.

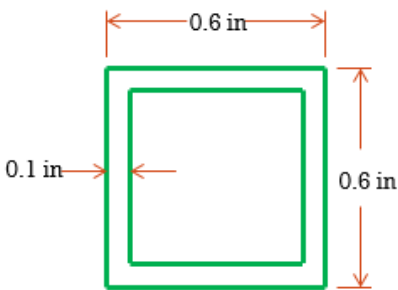

**Green beam**

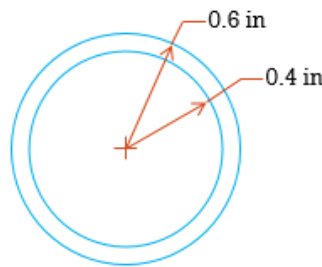

**Blue beam**

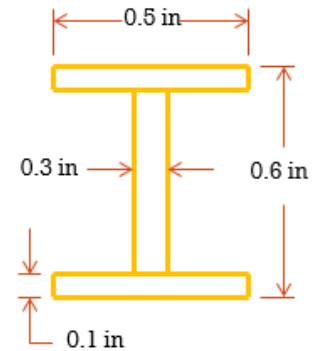

**Orange beam**

Using FEM (direct stiffness method) [50 points]

- Determine the maximum displacement in the light frame and its location.
- Determine the maximum axial force in the light frame and its location.
- Determine the maximum bending moment in the light frame and its location.

Using FEA (ANSYS Workbench) [50 points]

- Show the contour plots of the deformed shape with respect to the undeformed shape (mention the scale).
- Show the contour plot of the axial load.
- Show the contour plot of the bending moment.

Fill in the below table:

	FEM	FEA	%Error
Max Displacement (in)			
Max Axial Force (lb)			
Max Bending Moment (lb-in)			

Note: the wheels are not part of the frame.

**Assessment Rubric:** Assessment was performed using the rubric shown below. In each category the percentage and number of students (listed in parenthesis) achieving each criteria is reported.

N = 7 students	Unsatisfactory	Developing	Satisfactory	Exemplary
<b>Draw the finite element model for FEM calculations</b>	No finite element model drawing	Finite element model drawn, but not showing element number, node numbers, global and local coordinate directions	Finite element model drawn, showing element and node numbers, but not defining global and local coordinate axis  71.4% (5)	Finite element model drawn, showing element and node numbers, and global and local coordinate axis  28.6% (2)
<b>Local stiffness matrix of each element</b>	All the local stiffness matrices of the elements are wrong	Majority of the local stiffness matrices of the elements are wrong	Majority of the local stiffness matrices of the elements are right  57.1% (4)	All the local stiffness matrices of the elements are right  42.9% (3)
<b>Global stiffness matrix</b>	Completely wrong or not done	Attempted but most of the matrix terms are wrong due to compilation problem	A few terms (less than 10%) are wrong due to compilation or calculation errors  85.7% (6)	Completely right  14.3% (1)
<b>Boundary conditions (BC)</b>	Not defined any BCs or any defined BCs are wrong	Most of the BCs are defined and majority of them are right	All the BCs have been defined and most of them are right	All BCs defined and all of them are right  100% (7)
<b>Maximum displacement</b>	Not determined	Determined but conceptually wrong	Determined but calculation error(s)  85.7% (6)	Determined right  14.3% (1)



Using the equation $\{F\} = [K]\{u\}$ , calculate the unknown reactions.	Not calculated the unknown reactions	Calculated the unknown reactions wrong  14.3% (1)	Calculated the unknown reactions with some calculation errors  85.7% (6)	Calculated the unknown reactions with no calculation errors
Create the finite element model in ANSYS	Not created	Created but either dimensional errors, or wrong choice of elements, or wrong material properties defined, or a combination of these	Created but all the boundary conditions are not accurate	Created an accurate finite element model in ANSYS  100% (7)
Finite element analysis results	No contour plots shown  14.3% (1)	Only deformation contour plot shown	All contour plots shown but no comparison with undeformed shape	All contour plots shown and compared with undeformed shape  85.7% (6)
% Error	Calculation not done	Partially done  14.3% (1)	Done but majority of the errors above 20%  57.1% (4)	Done with majority of the errors below 20%  28.6% (2)

**Continuous Improvement:** For a relatively small class sample size of 7 students, there are no major concerns. Majority of the students are satisfactory or above.

### ET 400 Engineering Technology Internship Assessment (Fall 2016)

ABET learning outcomes assessed: c, g, h, k

UWGB general education outcome assessed: Writing Emphasis (WE)

ET 400 is the course assigned to the Engineering Technology internship. In addition to completing a minimum of a summer or semester long internship with a company in the appropriate field (electrical, environmental, mechanical engineering technology), each student will write a term paper documenting their experience and give an oral presentation at the end of the term. The course grade is based on

evaluation by the internship supervisor, the written paper, and the presentation. ABET learning outcomes, specific assignments used to assess each one, and assessment rubrics are discussed below.

**Criteria for the term paper are as follows:**

**Internship Experience Report:**

At the end of the internship semester, each student will write a 12 to 20 page paper (double spaced) detailing their experience. The paper should follow the outline below and include all of the information in the outline.

1. Describe the company, what products it makes, what the markets are for the products.
2. Describe the manufacturing process. Include applicable graphics to explain.
3. Describe your position with the company including responsibilities.
4. Describe projects that you worked on including the goals of the projects, any experiments or design work applied to the project; methods for measurements and analysis of measurements taken; results of any experiments or design work; and how processes were improved as a result
5. Discuss skills attained relevant to both engineering technology and a future professional career
6. Describe any opportunities for additional training/professional development and what skills were learned

This paper will also be used to assess the Writing Emphasis requirement of the course.

**ABET outcome c** states that the student will demonstrate: An ability to conduct standard tests and measurements; to conduct, analyze, and interpret experiments; and to apply experimental results to improve processes.

This outcome was assessed by both Prof. Patricia Terry and each student’s internship supervisor. Prof. Terry obtained the internship supervisor’s assessment via a phone conversation if an electronic copy of the evaluation was not completed. The assessment rubric and a summary of the results are given below.

**Assessment Rubric for ABET c:** Assessment by Prof. Terry (Assessed primarily from the paper) In each category the percentage and number of students (listed in parenthesis) achieving each criteria is reported.

N = 5	Unsatisfactory	Developing	Satisfactory	Exemplary
<b>Describe the purpose of measurements/ experimentation in context of process</b>	Description not adequate to explain what is being performed or why	Gives some information about the tests/ measurements	Adequately describes tests/Measurements and why they are performed  80% (4)	Comprehensive description of tests/measurements in the context of the overall process  20% (1)

<b>Properly conducts tests and collects data</b>	Fails to apply correct scientific method such that data is meaningless	Conducts tests with only minor errors and records inputs and outputs	Conducts tests using scientific methods and records inputs and outputs  80% (4)	Conducts tests using scientific methods and records data on all process parameters that might be affected  20% (1)
<b>Analyze data and interpret results</b>	Fails to apply appropriate models for analysis	Applies at least one model with no significant errors and interprets results based on this	Applies correct models to analyze data and interprets results specific to the tests  75% (3)	Applies all correct models to data analysis and interprets results in the context of the entire process  25% (1)
<b>Apply analysis for process improvement</b>	Makes incorrect changes to process	Makes process changes based on single model	Correctly applies analysis to process changes  50% (2)	Correctly applies analysis to process changes and documents improvement  50% (2)
<b>Document process improvement</b>	Fails to document results	Provides minimal documentation of process improvement	Document results of process improvement in a manner that allows replication  80% (4)	Documents results of process improvement in a manner that allows replication and suggests further tests/experiments  20% (1)

Note: some assessments were N/A based on projects.

**Assessment Rubric for ABET c:** Summary of internship supervisor reports. In each category the percentage and number of students (listed in parenthesis) achieving each criteria is reported.

<b>N = 5</b>	<b>Unsatisfactory</b>	<b>Developing</b>	<b>Satisfactory</b>	<b>Exemplary</b>
<b>Describe the purpose of measurements/ experimentation in context of process</b>	Description not adequate to explain what is being performed or why	Gives some information about the tests/ measurements	Adequately describes tests/ Measurements and why they are performed  40% (2)	Comprehensive description of tests/ measurements in the context of the overall process  60% (3)
<b>Properly conducts tests and collects data</b>	Fails to apply correct scientific method such that data is meaningless	Conducts tests with only minor errors and records inputs and outputs	Conducts tests using scientific methods and records inputs and outputs  60% (3)	Conducts tests using scientific methods and records data on all process parameters that might be affected  40% (2)
<b>Analyze data and interpret results</b>	Fails to apply appropriate models for analysis	Applies at least one model with no significant errors and interprets results based on this	Applies correct models to analyze data and interprets results specific to the tests  40% (2)	Applies all correct models to data analysis and interprets results in the context of the entire process  60% (3)
<b>Apply analysis for process improvement</b>	Makes incorrect changes to process	Makes process changes based on single model	Correctly applies analysis to process changes	Correctly applies analysis to process changes and documents improvement  100% (5)
<b>Document process improvement</b>	Fails to document results	Provides minimal documentation of process improvement	Document results of process improvement in a manner that allows replication  20% (1)	Documents results of process improvement in a manner that allows replication and suggests further tests/experiments  80% (4)

**ABET outcome g** states that the student will demonstrate: An ability to apply written, oral, and graphical communication in both technical and non-technical environments; and an ability to identify and use appropriate technical literature

The term paper was used to assess the written and graphical communication components of g: with rubric and summary of results below. Assessment performed by Prof. Terry. In each category the percentage and number of students (listed in parenthesis) achieving each criteria is reported.

<b>N = 5</b>	<b>Unsatisfactory</b>	<b>Developing</b>	<b>Satisfactory</b>	<b>Exemplary</b>
<b>Written articulation of experience</b>	Fails to articulate experience at all	Text rambles, repeated reading needed to understand, key points not organized	Articulates experience, but writing is somewhat difficult to follow 40% (2)	Articulates experience clearly and concisely 60% (3)
<b>Written organization</b>	Little to no structure or organization is used	Some structure and organization is used	Generally well organized, but some sections not clearly identified 40% (2)	Organized in a logical sequence to enhance readers' comprehension 60% (3)
<b>Professionally written to audience (professor and supervisors)</b>	Writing style is inappropriate for the audience and the assignment	Style is informal or inappropriate to audience 40% (2)	Usually uses professional, scientific writing style appropriate to audience 20% (1)	Uses excellent professional, scientific writing style to appropriate audience 40% (2)
<b>Quality of written work</b>	Work is not presented neatly; many spelling/ grammar errors 40% (2)	Work has more than 3 spelling or grammar errors per page; is somewhat messy 20% (1)	Work is presented neatly with few grammar or spelling errors	Work is presented neatly; grammar and spelling are correct 40% (2)

<b>Use of graphics: tables/graphs/figures</b>	No graphics are used  20% (1)	Graphics are presented, but flawed	Use of graphics is appropriate and usually in the correct format  40% (2)	Use of graphics is appropriate and all are in proper format  40% (2)
---	-------------------------------------	------------------------------------	---	--

**Assessment Rubric for ABET g (oral):** Each student gave a 12-15 minute presentation of their work and answered audience questions. The ET 101 class was the audience. In each category the percentage and number of students (listed in parenthesis) achieving each criteria is reported.

<b>N = 5</b>	<b>Unsatisfactory</b>	<b>Developing</b>	<b>Satisfactory</b>	<b>Exemplary</b>
<b>Oral articulation of experience</b>	Fails to articulate experience at all	Speaker rambles, key points not organized	Articulates experience but somewhat difficult to follow	Articulates experience clearly and concisely  100% (5)
<b>Presentation organization</b>	Little to no structure or organization is used	Some structure and organization is used	Generally well organized  40% (2)	Organized in a logical sequence to enhance comprehension  60% (3)
<b>Presentation quality</b>	Student not prepared, presentation not appropriate	Style is informal or inappropriate to audience	Student mostly prepared; presentation is appropriate to audience  20% (1)	Student very well prepared, knowledgeable; presentation is appropriate to audience  80% (4)
<b>Use of graphics: tables/graphs/figures</b>	No graphics are used	Graphics are presented, but flawed	Use of graphics is appropriate and usually in the correct format  20% (1)	Use of graphics is appropriate and all are in proper format  80% (4)

<b>Stays within time limits</b>	Student goes significantly over time limit (more than 6 minutes)	Student goes a little over time limit (about 3-5 minutes) or significantly under	Student is within 2 minutes of time limit 20% (1)	Presentation exactly meets time requirement 80% (4)
<b>Answers questions</b>	Student unable or unwilling to answer questions	Student attempts to answer questions, but in a rambling, insufficient manner	Student answers questions in an acceptable manner 40% (2)	Student willingly and concisely answers all relevant questions 60% (3)

**ABET outcome h** states that the student will demonstrate: An understanding of the need for and an ability to engage in self-directed continuing professional development

This outcome will be assessed both by the internship supervisor through interaction with the student and by Professor Terry through the internship report.

**Assessment Rubric for ABET h:** Prof. Terry. In each category the percentage and number of students (listed in parenthesis) achieving each criteria is reported.

<b>N = 5</b>	<b>Unsatisfactory</b>	<b>Developing</b>	<b>Satisfactory</b>	<b>Exemplary</b>
<b>Student seeks professional development opportunities through internship</b>	Shows no interest in opportunities offered	Participates in opportunities only when required	Takes advantage of opportunities offered during internship 100% (5)	Actively seeks opportunities through internship supervisor
<b>Student seeks professional development opportunities outside of internship</b>	Participates in no professional or extra-curricular organizations	Participates in activities when required by a class	Takes advantage of activities offered by faculty 60% (3)	Actively seeks opportunities within professional societies or campus activities 40% (2)

<b>Has knowledge of professional societies</b>	Fails to identify or join professional societies	Identifies professional societies 60% (3)	Joins professional society 40% (2)	Joins professional society and actively engages on local chapter
--	--	--	---------------------------------------	--

**Assessment Rubric for ABET h:** Internship supervisor

In each category the percentage and number of students (listed in parenthesis) achieving each criteria is reported.

<b>N = 5</b>	<b>Unsatisfactory</b>	<b>Developing</b>	<b>Satisfactory</b>	<b>Exemplary</b>
<b>Student seeks professional development opportunities through internship</b>	Shows no interest in opportunities offered	Participates in opportunities only when required	Takes advantage of opportunities offered during internship 60% (3)	Actively seeks opportunities through internship supervisor 40% (2)
<b>Student seeks professional development opportunities outside of internship</b>	Participates in no professional or extra-curricular organizations	Participates in activities when required by a class	Takes advantage of activities offered by faculty 50% (2)	Actively seeks opportunities within professional societies or campus activities 50% (2)
<b>Has knowledge of professional societies</b>	Fails to identify or join professional societies	Identifies professional societies 25% (1)	Joins professional society 75% (3)	Joins professional society and actively engages on local chapter

Note: Internship supervisors marked some as N/A, so for these n = 4.

**ABET outcome k** states that the student will demonstrate a: Commitment to quality, timeliness, and continuous improvement.



This outcome will be assessed by the internship field supervisor and sent to Professor Terry. In each category the percentage and number of students (listed in parenthesis) achieving each criteria is reported.

**Assessment Rubric for ABET k:**

<b>N = 5</b>	<b>Unsatisfactory</b>	<b>Developing</b>	<b>Satisfactory</b>	<b>Exemplary</b>
<b>Demonstrates reliability</b>	Does not reliably come to work on agreed upon schedule and misses meetings	Misses more than once a month without an acceptable reason; occasionally misses meeting	Rarely misses work and gives appropriate notification; never misses meetings	Only misses work for acceptable reasons and notifies supervisor in a timely manner; never misses meetings  100% (5)
<b>Demonstrates commitment to timeliness</b>	Often fails to arrive on time to work or meetings	Is late to work more than once a week or is late to or meetings	Rarely arrives late for work or meetings	Always arrives to work or meetings on time  100% (5)
<b>Demonstrates commitment to quality</b>	Quality of work is unacceptable	Quality of work needs significant improvement	Quality meets expectations for a student intern	Quality significantly exceeds expectations for a student intern  100% (5)
<b>Demonstrates commitment to improvement</b>	Does not take direction well; ignores feedback	Sometimes takes direction well; sometimes open to feedback	Usually takes direction well; usually incorporates feedback into work	Always takes direction well; open to feedback and incorporates into work  100% (5)
<b>Would you hire this student?</b>	no	Possibly after graduation if significant growth occurs	Would consider for an open position.  20% (1)	Absolutely, with no reservations.  80% (4)

This course also meets the UW-Green Bay general education learning outcome for Writing Emphasis.

**Assessment Rubric for Writing Emphasis: Term paper is assessed by Prof. Terry**

In each category the percentage and number of students (listed in parenthesis) achieving each criteria is reported.

N = 5	Unsatisfactory	Developing	Satisfactory	Exemplary
<b>Paper includes all required components</b>	Only two or three components are covered and not all at adequate level	Most components are included and most are at adequate level	Paper includes all required components 80% (4)	Paper gives thorough description of all components 20% (1)
<b>Paper is well organized</b>	Paper is not organized at all	Paper has some organization, but inconsistent	Paper is organized according to the questions asked, but not well organized overall 20% (1)	Paper is organized according to topics and overall into an easy to follow flow of information 80% (4)
<b>Correct grammar and spelling are used throughout</b>	Grammar and spelling are poor – many errors per page 40% (2)	Grammar and spelling are marginally acceptable – 2 to 3 errors per page 20% (1)	Grammar and spelling are good – no more than one error per page	Grammar and spelling are near perfect – no more than 3 errors in entire paper 40% (2)
<b>Tables and figures illustrate concepts</b>	No tables or figures are provided 20% (1)	One figure or table is given – a map of area 20% (1)	Tables and figures illustrate some concepts 20% (1)	Tables and figures completely support the text 40% (2)

**Continuous improvement:**

**ABET c:** Students generally did fine with ABET learning outcome c. Students complete the internship usually after the junior year, so students have had many lab and field classes in which to practice proper experimental technique and data analysis. In the future I may encourage field supervisors to have students more completely document process improvement through data collection and report this to a greater extent in their term papers and presentations.

**ABET g Written and graphical communication:** While students articulated their experiences in an organized paper, emphasis needs to be placed on writing for the appropriate audience and minimizing

grammatical errors. In the lower level Engineering technology classes the faculty should give examples of technical writing for an appropriate audience.

**ABET g oral communication:** Students did surprisingly well and stayed within the time limits in well-organized, interesting presentations. It is a good idea to continue having the fall semester internship students present to the Introduction to ET class because it gives the Intro. students the opportunity to see good presentations modeled. Of course, the quality of presentation is dependent on the particular student and may not be as good next semester. We should consider incorporating good presentation skills into the Intro. class.

**ABET h:** Both Prof. Terry and the Field Supervisors gave the students acceptable marks for engaging in professional development. While opportunities on campus exists for all students, not all internships provide equal opportunity. In future conversations with field supervisors, Prof. Terry will encourage them to include student interns in career development opportunities given to all employees where appropriate. Throughout all ET classes at UWGB, students need greater encouragement to join students chapters of professional organizations.

**ABET k:** Internship supervisors gave very high marks to all students, but perhaps this was because they were conducted via phone interview. This semester, it would be a good idea to find a mechanism for anonymous feed back in case a field supervisor feels any score less than perfect may impact a student's grade. It could also be that UWGB students tend to be working or middle class and expect to work to help pay for their educations and, hence, they developed a good work ethic at a young age.

**Writing Emphasis:** As expected, students overall wrote well organized papers with required content, but grammar and spelling continue to be a challenge. We may need to consider a course specific to technical writing skills or, at least, spend some time in lower level courses emphasizing writing grammatically correct English.