

Professional Programs in Business

Majors and Minors in:

**Accounting
And
Business Administration**
Finance
Human Resource Management
Management
Marketing



UNIVERSITY *of* WISCONSIN

GREEN BAY

**Undergraduate
Advising Handbook**

www.uwgb.edu/busadmin

What is the difference between a job and a career? A job is what you get for knowing how to do a few things well. A career is a lifetime of opportunity and learning. The Professional Programs in Business Department at the University of Wisconsin-Green Bay is in the career business.

This handbook and your business or accounting advisor will help you choose your path to a college degree in Business Administration and/or Accounting which represents much more than job skills. It means the kind of broad background in business which makes you a candidate for leadership in your chosen field. It means your specialty -- accounting, finance, management or marketing -- is enhanced by a good understanding of other specialties and business in general. It means you have completed a college program known for its excellence and effectiveness.

Does it sound challenging? Keep this in mind: we're on *your* side. We want to help you discover and enhance your potential for success in business and life.

**The Faculty and Staff of the
Professional Programs in Business
University of Wisconsin-Green Bay**

CONTENTS

Our Mission -----	1
Learning Outcomes -----	3
Advising Information -----	4
Policies -----	6
The Major and Minor in Business Administration	
Introduction -----	10
Business Administration Major , Finance Emphasis-----	12
Business Administration Major , Management Emphasis-----	13
Business Administration Major , Human Resource Mgmt Emphasis -----	14
Business Administration Major , Marketing Emphasis -----	15
Business Administration Minor -----	16
International Business Minor -----	17
The Major and Minor in Accounting	
Introduction -----	18
Accounting Major -----	22
Accounting Minor -----	23
Associate of Arts Degree in Business Administration -----	24
Course List -----	25
Course Descriptions	
Accounting -----	26
Business Administration	
Finance-----	29
General-----	31
Management-----	32
Marketing -----	34
Quantitative Methods / MIS -----	35
Faculty and Staff Directory -----	Inside back cover

The Professional Programs in Business Undergraduate Advising Handbook is designed to assist Undergraduate Business Administration and Accounting majors and minors with their program planning, and does not establish a contractual commitment. This Advising Handbook describes the programs, policies, rules, regulations and procedures of Business Administration and Accounting undergraduate programs in effect at the time of printing. These may be subject to change. The University and the faculty in Business Administration and Accounting reserve the right to modify any program, policy, rule, regulation, and/or procedure without prior notification. Students are encouraged to consult regularly with the advisors in the Office of Academic Advising and their faculty advisor in Business Administration or Accounting to ensure that they have the latest information.

Updated 11/07/08

OUR MISSION

Every organization exists to accomplish something that serves the larger environment. That "something" is the organization's purpose, or mission. The mission statement is a long-run vision of what the organization is trying to become — the uniqueness that separates it from similar organizations. The mission statement provides direction and significance to all members of the organization. It communicates to them why they do what they do and why it matters.

The faculty and staff of Business Administration and Accounting have developed and approved the following mission statement for the Professional Programs in Business. The mission statement is offered here to help you understand what these programs are about. The statement changes as the department changes to meet the demands of the environment.

University of Wisconsin-Green Bay Professional Programs in Business Mission Statement

We provide a high quality, University education to our students at the undergraduate level that meets the needs of business, industry and organizations throughout Northeastern Wisconsin. Our core purpose is to graduate professionally educated students who can manage, build and sustain the success and the quality of business, be a source of leadership (*be a productive citizen*) in the communities of our region and pursue further education.

We are committed to providing the highest level of teaching quality, to reflect the values and culture of our region, to prepare our students with the latest in management technology and to make our professional expertise available through research and service. We are a professional program of the University of Wisconsin-Green Bay.

TEACHING

Our primary objective is to **teach** Business Administration and Accounting to prepare our undergraduate students to succeed in their postgraduate careers and to become leaders within their organizations and their communities. We also participate, as resources permit, in cooperative graduate programs and general education. Fifty percent of our total effort is dedicated to teaching.

Our programs draw upon the unique strengths of UW-Green Bay by providing significant exposure to the liberal arts and a sound foundation in the ideas, concepts, and skills of business and accounting. The Business Administration curriculum is interdisciplinary and problem-focused, providing a broad background in business and the opportunity for a more in-depth study of finance, management or marketing. The Accounting curriculum is disciplinary and provides an intensive study of financial and managerial accounting. Through this education, we develop our students' critical thinking, problem solving, interpersonal, communication, and quantitative and technological skills. In addition, we address complex and contemporary organizational issues such as competing in the global marketplace, understanding the relationship between organizations and their environments, total quality management and the role of social responsibility and ethics in organizations.

INTELLECTUAL CONTRIBUTIONS

We are committed to the creation of **intellectual contributions** that augment existing organizational theories and practices and that support continuously improving business instruction in higher education. Thirty percent of our total effort is dedicated to intellectual contributions.

Reflecting our regional responsibility and the emphasis on undergraduate teaching as our primary mission, the focus of our intellectual contributions is in the areas of applied and instructional knowledge, with some contribution to basic knowledge. Since complex issues are best addressed from multiple perspectives, interdisciplinary intellectual contributions are encouraged. Faculty and staff are committed to continuously develop and maintain their intellectual capital.

SERVICE

We are dedicated to providing our expertise and knowledge through **service** activities. Twenty percent of our total effort is dedicated to service.

We participate fully in UW-Green Bay's unique system of shared governance, through which faculty and staff, students and administrators are partners in the institution's decision-making processes. In addition to general obligations of good citizenship and collegiality, we recognize the special obligation we have to participate in shared governance through service on and leadership of departmental and university-wide committees, councils and task forces because of our academic understanding of organizations and their environments.

We are actively involved in the regional community through our contributions to continuing business education, membership in professional organizations, sharing of professional expertise and through other formal and informal interactions at the campus and community levels.

LEARNING OUTCOMES

Following are the learning outcomes that all Accounting and Business Administration majors, regardless of emphasis, should be able to demonstrate by the time they complete their studies.

1. **Disciplinary and “Sub-disciplinary” Knowledge:** Students should demonstrate their basic knowledge and comprehension of the disciplines in accounting, finance, law, management and marketing.
2. **Communication:** Students should demonstrate their ability to present, discuss and defend views effectively through spoken and written language.
3. **Computer Skills:** Students should demonstrate their ability to use technology to locate, obtain, organize, report and use information from electronic sources.
4. **Group Participation:** Students should demonstrate their ability to work with, influence and lead others, organize and delegate tasks, motivate and develop people and withstand and resolve conflict.
5. **Quantitative Analysis:** Students should demonstrate their ability to apply quantitative analytical processes to solving problems.
6. **Critical Thinking:** Students should demonstrate their capacity for inquiry, abstract logical thinking, inductive and deductive reasoning and critical analysis in understanding and implementing concepts and theories.
7. **Problem Solving:** Students should demonstrate their ability to identify and solve unstructured problems in unfamiliar settings and to apply problem-solving skills to real world problems.
8. **Ethics in Decision Making:** Students should demonstrate their ability to identify, reason and seek resolution of ethical issues.
9. **Economic Globalization:** Students should demonstrate their awareness of economic globalization and its effects.
10. **Practical Applications:** Students should demonstrate their understanding of the practical applications of principles and theories through working with applied business problems and projects.
11. **Interdisciplinarity:** Students should demonstrate their ability to apply a synthesis of different disciplines when solving problems.

ADVISING INFORMATION

This handbook is for students considering a major or minor in Business Administration and/or Accounting. Various publications have been designed by UW-Green Bay's faculty and staff to facilitate your college experience. You are encouraged to review each of them, and be aware of their contents. These publications, and the offices which provide them, include:

<u>Publication</u>	<u>Source</u>
UW-Green Bay Undergraduate Catalog	Bookstore
Student Handbook	Dean of Students
Schedule of Classes	Registrar's Office

The Academic Plan for Business Administration and Accounting Majors

All UW-Green Bay students are expected to file a plan for the major by the time 62 credits are earned and/or in progress. The plan is created by submitting the form, "Official Declaration of Degree Plan/Advisor" to the Registrar's Office. This form is used to declare, change or delete majors/minors, as well as to designate an official faculty advisor. It will create an advisement report, a personalized list of all course required for the degree including General Education courses and courses required for the major and minor. Your advisement report (commonly referred to as an academic plan) is available through the Student Information System. Each semester the computer updates your plan, providing you with up to date and accurate information. You may view the updated information on the computer or obtain a printout of your plan at a minimal cost through the Computer Center. The advantages of having your plan on file are obvious. The guesswork will be taken out of your schedule planning and there is greater likelihood of completing requirements in a more timely fashion.

In order to file the "Official Declaration of Degree Plan/Advisor" form you must have satisfied the admission criteria for the major, i.e.: 36 earned credits with a minimum 2.5 cumulative grade point average. Refer to the information on admission criteria found on page 7 of this handbook (Entrance Requirements). We encourage you to file your plan as soon as you have earned at least 36 credits and you have been admitted to either Business Administration or Accounting, with a classification of either BUA or ACTG. There is no need to wait until you have 62 credits. To begin the process, pick up the form from the Registrar's Office or the Academic Advising Office.

Your second step is to arrange an appointment with your faculty advisor from Business Administration or Accounting. Call the Professional Programs in Business office at 465-2051 to find out who your faculty advisor will be. Each academic year an advising schedule is available indicating each area of emphasis within Business Administration and Accounting and the appropriate advisor to contact. You will be given the faculty advisor's direct telephone number and office hours so that an appointment can be made. **IT IS BEST TO CALL IN ADVANCE FOR AN APPOINTMENT!**

The third step requires you to select a minor and meet with the faculty advisor in that area. If you are unsure of your intended minor, discuss it with your faculty advisor from Business Administration or Accounting. A list of advisors for all areas of study, office locations and phone numbers is available in the current Schedule of Classes. ***Please note that all Business Administration majors are required to complete a minor outside of Business Administration. Accounting majors will automatically complete a Business Administration minor through their required Accounting course work.***

Your last step is to submit the form to the Registrar's Office. Shortly thereafter you will have access to your academic plan through the Student Information System.

Note to Transfer Students

All students must satisfy degree residency requirements including minimum credit residency requirements for the major and minor. Consult with your advisor and/or refer to your SIS advisement report to ensure completion of the residency requirements if you are intending to use transfer courses to satisfy any Business Administration or Accounting major or minor requirements.

POLICIES

The faculty of the Professional Programs in Business expect you to observe the ancient academic traditions — such as attending classes, meeting prerequisites, and promptly communicating with your instructor when you can't meet expectations. We take your investment of time in college, and your future in business seriously. The required courses, their content and structure, represent the tools you will need to succeed in the career you choose.

The following policies set the ground rules for success in your program. In addition to those that follow, you should familiarize yourself with the rules, regulations, policies and procedures found in the current Schedule of Classes, Catalog and Student Handbook.

Class Attendance

Full attendance of classes is expected. If you are unable to attend during the first week of classes you must notify the instructor(s), in writing, of the reason for missing class and your intent to complete the course(s). Failure to attend classes during the first week of the semester, without prior notification, may result in an administrative drop by the course instructor. Failure to complete a formal course drop prior to the course drop deadlines will result in a failing grade in the course.

Having to work does not constitute a valid excuse for missing class, examinations and/or other deadlines. You should ensure that your work and class schedules do not conflict prior to the start of classes.

Class Conduct

Behavior which distracts the class from meeting course objectives (e.g., unsuitable talking, eating, drinking, late arrival) may result in an administrative drop by the instructor.

Closed Courses

Certain courses have enrollment limits to ensure the quality of the educational environment. First access to these courses is given to those close to completing their degree work.

Your best chance to gain entrance to a closed course is to check regularly at the Registrar's Office to see if any previously registered students have dropped the course. There are almost always some drops between registration and the beginning of the semester. Such openings are awarded on a first come - first served basis by the Registrar's Office.

Your next opportunity is to visit your desired class on the first day of its meeting. On the first day, when the course registration has reached the limit, faculty members may drop any enrolled student who has not made an appearance and who has failed to notify the instructor with an explanation *in advance*. Thus, you may gain entry at that time — again, on a first come - first served basis at the Registrar's Office.

Computer Usage

The time to acquaint yourself with a computer is now. The rapidly changing world demands that we process ever-greater amounts of information in less and less time. You will be well served in the job market if you have acquired word processing, spreadsheet, database and other computer software skills.

Many students prefer to purchase their own personal computer and printer. If you are considering this option it is recommended that you contact Computing and Information Resources (465-2309) for minimum recommended configurations.

Students can purchase software applications through the Phoenix Bookstore at significant discounts.

Drop Deadlines

You are responsible for knowing drop deadlines for all of your courses! If a course does not meet your needs, you should drop the course early so that other students may add it.

The following Accounting courses have a separate drop policy: 300, 301, 302, 312, 313, 314, 316, 452 (cross-listed as BUS ADM 452 also). Students dropping any of these courses after the first two weeks of class or receiving an F in the course will be automatically placed on the waitlist (rather than given priority registration based on number of credits earned) for that course for subsequent semesters. Requests to be removed from the waitlist must be approved by the Department Chair.

Feedback in the form of grades on papers or examinations does not justify a late drop.

Entrance Requirements

To be admitted to either the Business Administration or Accounting major or minor, with a classification of BUA or ACTG, a student must meet minimum standards established by the Professional Programs in Business faculty. To be admitted to the Business Administration or Accounting major or minor, a student must have a minimum 2.5 grade point average on a total of at least 36 earned degree credits. Transfer students with less than 36 degree credits and/or a grade point average of less than 2.5 must earn 15 degree credits at UW-Green Bay and have a minimum 2.5 grade point average on those credits prior to admission to the Business Administration or Accounting major or minor.

Transfer credits are included in the grade point calculation. Eligibility does not guarantee admission. Only the most qualified applicants, based upon grade point average, are admitted from the pool of eligible students. The number of students admitted is determined by availability of faculty, enrollment levels and other considerations.

Exit Requirement

All students wanting to graduate with a major in Business Administration and /or Accounting must have a minimum 2.5 cumulative grade point average *regardless of their matriculation date.*

There are no exceptions to this policy.

Final Exams

The office of the Provost/Vice Chancellor for Academic Affairs determines the final examination schedule. You are responsible for knowing the final examination policies and dates as printed in the Schedule of Classes. While an instructor may (at his or her discretion) reschedule your final exam, you are not guaranteed such an opportunity.

"Gateway Course" Requirements

All students must have a minimum of 36 earned credits with a minimum 2.5 grade point average to enroll in the following "gateway courses":

ACCTG 305	Legal Environment of Business
BUS ADM 322	Introductory Marketing
BUS ADM 343	Corporation Finance
BUS ADM 382	Introductory Management

In addition, BUS ADM 322, BUS ADM 343 and BUS ADM 382 have other prerequisites. See the "Course Descriptions" beginning on page 24 of this Handbook for specific information on course prerequisites.

Grades and Grade Appeals

You will receive a grade from the instructor of the course at the end of the respective semester. If you are dissatisfied with a course grade, you must first meet with the **instructor** to discuss and request a review of the grade. If you are dissatisfied with the review of the grade, you may appeal the review through the following individuals:

- a. For Business Administration courses: (1) the Business Administration Chairperson; and (2) the Dean of Professional and Graduate Studies.
- b. For Accounting courses: (1) the Accounting Chairperson; and (2) the Dean of Professional and Graduate Studies.

These individuals act in an advisory capacity to you and the instructor. Only the instructor has the authority to change grades.

Independent Study / Internships

Students interested in doing advanced study may do so via independent study. Independent studies provide the opportunity to develop your own course in an area not covered by current classes. Illustratively, students doing an independent study may expand their research skills, read primary literature and/or write major papers. Those interested in such an opportunity should talk with their advisor.

Through University-arranged internships, students earn academic credit (often a salary as well) for working and learning on campus, or with business and nonprofit organizations in the community. While students will earn academic credit for participating in an internship, this credit cannot be used to satisfy any Business Administration or Accounting major or minor degree requirements. Internships are taken on a pass-fail basis. Internships are arranged with the help of the Internship Coordinator, Brent Hussin, who may be contacted at 465-2575 or hussinb@uwgb.edu. See www.uwgb.edu/hussinb/internships.htm for more information on Business Administration and Accounting internships. Also see page 19 of this handbook for additional information specific to Accounting internships.

Interested students should start seeking information at the end of their sophomore year and plan accordingly. **Participation in Independent Study and/or Internships is strongly encouraged for all Business Administration and Accounting students.**

Late Policies

- a. **Exams:** There will be no makeup exams if you miss the regularly scheduled time, unless prior arrangements are made with the instructor. If circumstances do not allow this, you will be asked to provide proof of your reason for missing an exam. You are not guaranteed the opportunity to make-up the missed exam.
- b. **Projects:** All projects and assignments must be delivered to the instructor on the specified day. The course instructor must approve any exceptions in advance.

All assignments must conform to the UW-Green Bay writing policy in the Student Handbook. These writing policies are not arbitrary. They represent common standards of literacy and written communication observed by institutions of higher education internationally.

Writing Emphasis Courses

Several Business Administration and Accounting courses are designed to improve and reinforce your writing skills through regular opportunities to practice your skills on diverse projects. Courses which meet the writing emphasis requirements of the campus are designated with the letters "**WE**" throughout this publication. Since all UW-Green Bay students are required to complete at least four "**WE**" courses, you should consult with your faculty advisor to ensure that you will fulfill this requirement.

The Major and Minor in **BUSINESS ADMINISTRATION** *(interdisciplinary)*

Both the Business Administration major and minor are interdisciplinary. "Interdisciplinary" means that while Business Administration students study a particular subject (e.g., finance, management, marketing), they also examine how it relates to other subjects and draw information from various disciplines to solve "business" problems. In addition to preparing for a career in finance, management or marketing, Business Administration students examine how their career fits into the context of other endeavors. The ability to understand the complex and interdependent issues, to view problems and opportunities from many perspectives and to work with those from other fields are qualities in demand. UW-Green Bay Business Administration majors graduate with a distinct advantage over traditional business school graduates.

More than 90 percent of UW-Green Bay Business Administration graduates find employment in their chosen career within six months of graduation. Those interested in graduate studies are accepted into the better schools. Many alumni are successful business leaders. Alumni surveys indicate that alumni perceive the Business Administration program very favorably, their program of study prepared them extremely well for their careers, the quality of the Business Administration faculty is "excellent" and they would definitely recommend the program to others.

These successes may be attributed to Business Administration's broad array of contemporary, professional business courses, a dedication to teaching excellence and to an emphasis on the skills basic to career advancement such as effective writing, speaking, quantitative analysis, computer proficiency, decision making and problem solving.

Business Administration faculty are committed to serving the needs of business and society, and to providing an outstanding learning environment. Upper-division classes frequently number fewer than 35 students, facilitating discussion and the opportunity to work closely with faculty. About one-third of the Business Administration courses are offered late afternoons and evenings to accommodate employed students.

The Business Administration program addresses contemporary business issues, including economic globalization, continuous quality improvement and business ethics. These issues and more are addressed in specific classes and throughout the curriculum. Today's businesses require employees who are effective communicators and problem solvers with broad-based liberal educations. Business Administration students take courses which develop their communication skills and they gain breadth through courses in the arts, humanities, social sciences and natural sciences. Each business major studies an area of emphasis extensively: finance, general management, human resources, or marketing. Each emphasis consists of courses designed to thoroughly prepare the student in a business specialization. Students also develop expertise and problem-solving proficiency in at least one other field by completing a non-business minor.

The required non-business minor may be used in many productive ways. Students with quantitative and communication interests may complete a minor in communication processes or information and computing science, and prepare for careers in information systems development, technical business communication and the like. Those interested in human services may minor in human development or psychology and pursue such careers as child and elder care administration or corporate wellness. Many possibilities exist. Business Administration advisors will help you plan a program that meets your personal and professional goals.

Extensive opportunities are available to meet business professionals and to gain practical experience. Active student organizations provide opportunities to meet others with like interests and to develop contacts with businesses. The majority of upper-division courses include a practical, major project component, giving you the opportunity to apply the theories and concepts learned in the classroom to real situations. Participation in the internship program is encouraged. Here students learn while working in an actual business setting. Many students continue working full-time for their internship sponsors upon graduation.

GENERAL EDUCATION REQUIREMENTS

In addition to the requirements outlined on the following pages, everyone wishing to Major or Minor in Business Administration, regardless of emphasis, is required to complete the general education requirements of the University of Wisconsin--Green Bay. These requirements are detailed in the University of Wisconsin--Green Bay Undergraduate Catalog and can also be found at <http://www.uwgb.edu/catalog/undrgrad/gened.htm>.

BUSINESS ADMINISTRATION MAJOR

FINANCE EMPHASIS

[] Check when completed

[]	I.	REQUIRED SUPPORTING COURSES (six)	18-19 credits
[]	1.	BUS ADM 215 Intro. to Business Stats (F,S) (or MATH 260 4cr.)	3 cr.
[]	2.	BUS ADM 217 Advanced Business Statistics (F,S)	3 cr.
[]	3.	BUS ADM 350 Business Computer Applications (F,S)	3 cr.
[]	4.	ECON 202 Macroeconomic Analysis (F,S)	3 cr.
[]	5.	ECON 203 Microeconomic Analysis (F,S)	3 cr.
[]	6.	ENG COMP 105 Expository Writing (F,S)**	3 cr.
		(**Waived with ACT English score of 32 or higher)	
[]	II.	REQUIRED CORE COURSES (ten)	31 credits
[]	1.	ACCTG 300 Introductory Accounting (F,S)	4 cr.
[]	2.	ACCTG 302 Managerial Accounting I (F,S)	3 cr.
[]	3.	ACCTG 305 Legal Environment of Business (F,S) *	3 cr.
[]	4.	BUS ADM 322 Introductory Marketing (F,S) *	3 cr.
[]	5.	BUS ADM 343 Corporation Finance (F,S) *	3 cr.
[]	6.	BUS ADM 347 Financial Markets and Institutions (F,S)	3 cr.
[]	7.	BUS ADM 382 Introductory Management (F,S) *	3 cr.
[]	8.	BUS ADM 389 Organizational Behavior (F,S)	
		(or any BUS ADM 38X/48X or BUS ADM 36X/46X or BUS ADM 472 or ACCTG/BUS ADM 452)	
[]	9.	BUS ADM 428 Consumer Behavior (F,S) <i>WE</i>	
		(or any BUS ADM 32X/42X)	
[]	10.	BUS ADM 490 Strategic Decision Analysis (capstone) (F,S)	3 cr.
[]	III.	REQUIRED FINANCE EMPHASIS COURSES (four)	12 credits
[]	1.	BUS ADM 442 Principles of Investments (F,S) <i>WE</i>	3 cr.
[]	2.	BUS ADM 445 International Financial Management (S)	3 cr.
[]	3.	BUS ADM 446 Advanced Corporation Finance (F,S)	3 cr.
[]	4.	One of the following:	
		BUS ADM 344 Real Estate Principles (S)	3 cr.
		BUS ADM 345 Risk Management and Insurance (F)	3 cr.
		BUS ADM 447 Advanced Investments (F)	3 cr.
		BUS ADM 450 Bank Administration (F)	3 cr.
[]	IV.	REQUIRED MINOR	18 credits

All Business Administration students must choose a minor other than Business Administration or International Business. Recommended minors include: Accounting, Communication Processes, Economics, Psychology, Information Science, Humanistic Studies or any foreign language. Others of your choice are also accepted.

* Denotes a "Gateway Course" -- Refer to page 8 for more information.

Consult with your Business Administration--Finance advisor for appropriate substitutions for any of the listed courses.

BUSINESS ADMINISTRATION MAJOR MANAGEMENT EMPHASIS

[] Check when completed

[]	I.	REQUIRED SUPPORTING COURSES (six)	18-19 credits
[]	1.	BUS ADM 215 Intro. to Business Statistics (F,S) (or MATH 260 4cr.)	3 cr.
[]	2.	BUS ADM 217 Advanced Business Statistics (F,S)	3 cr.
[]	3.	BUS ADM 350 Business Computer Applications (F,S)	3 cr.
[]	4.	ECON 202 Macroeconomic Analysis (F,S)	3 cr.
[]	5.	ECON 203 Microeconomic Analysis (F,S)	3 cr.
[]	6.	ENG COMP 105 Expository Writing (F,S)**	3 cr.
		(**Waived with ACT English score of 32 or higher)	
[]	II.	REQUIRED CORE COURSES (ten)	31 credits
[]	1.	ACCTG 300 Introductory Accounting (F,S)	4 cr.
[]	2.	ACCTG 302 Managerial Accounting I (F,S)	3 cr.
[]	3.	ACCTG 305 Legal Environment of Business (F,S) *	3 cr.
[]	4.	BUS ADM 322 Introductory Marketing (F,S) *	3 cr.
[]	5.	BUS ADM 343 Corporation Finance (F,S) *	3 cr.
[]	6.	BUS ADM 347 Financial Markets and Institutions (F,S) (or any BUS ADM 34X/44X or BUS ADM 450)	3 cr.
[]	7.	BUS ADM 382 Introductory Management (F,S) *	3 cr.
[]	8.	BUS ADM 389 Organizational Behavior (F,S)	3 cr.
[]	9.	BUS ADM 428 Consumer Behavior (F,S) WE (or any BUS ADM 32X/42X)	3 cr.
[]	10.	BUS ADM 490 Strategic Decision Analysis (capstone) (F,S)	3 cr.
[]	III.	REQUIRED GENERAL MANAGEMENT EMPHASIS COURSES (four)	12 credits
[]	1.	BUS ADM 482 Strategic Management (S)	3 cr.
[]	2.	BUS ADM 489 Organizational Theory (F,S) WE	3 cr.
[]	3.	Two of the following:	
[]	4.	BUS ADM 362 Human Resource Management (F,S)	3 cr.
		BUS ADM 384 Production/Operations Management (S)	3 cr.
		BUS ADM 386 Field Project in Business Management (F)	3 cr.
		BUS ADM 452 Adv. Microcomputer Business Applic (F,S)	3 cr.
		BUS ADM 472 Seminar in Leadership (F) WE	3 cr.
		BUS ADM 480 Quality Management (F,S) WE	3 cr.
[]	IV.	REQUIRED MINOR	18 credits

All Business Administration students must choose a minor other than Business Administration or International Business. Recommended minors include: Accounting, Communication Processes, Economics, Psychology, Information Science, Humanistic Studies or any foreign language. Others of your choice are also accepted.

* Denotes a "Gateway Course" -- Refer to page 8 for more information.

Consult with your Business Administration--Management advisor for appropriate substitutions for any of the listed courses.

BUSINESS ADMINISTRATION MAJOR

HUMAN RESOURCE MANAGEMENT EMPHASIS

[] Check when completed

[]	I.	REQUIRED SUPPORTING COURSES (six)	18-19 credits
[]	1.	BUS ADM 215 Intro. to Business Statistics (F,S) (or MATH 260 4cr.)	3 cr.
[]	2.	BUS ADM 217 Advanced Business Statistics (F,S)	3 cr.
[]	3.	BUS ADM 350 Business Computer Applications (F,S)	3 cr.
[]	4.	ECON 202 Macroeconomic Analysis (F,S)	3 cr.
[]	5.	ECON 203 Microeconomic Analysis (F,S)	3 cr.
[]	6.	ENG COMP 105 Expository Writing (F,S)**	3 cr.
		(**Waived with ACT English score of 32 or higher)	
[]	II.	REQUIRED CORE COURSES (ten)	31 credits
[]	1.	ACCTG 300 Introductory Accounting (F,S)	4 cr.
[]	2.	ACCTG 302 Managerial Accounting I (F,S)	3 cr.
[]	3.	ACCTG 305 Legal Environment of Business (F,S) *	3 cr.
[]	4.	BUS ADM 322 Introductory Marketing (F,S) *	3 cr.
[]	5.	BUS ADM 343 Corporation Finance (F,S) *	3 cr.
[]	6.	BUS ADM 347 Financial Markets and Institutions (F,S) (or any BUS ADM 34X/44X or BUS ADM 450)	3 cr.
[]	7.	BUS ADM 382 Introductory Management (F,S) *	3 cr.
[]	8.	BUS ADM 389 Organizational Behavior (F,S)	3 cr.
[]	9.	BUS ADM 428 Consumer Behavior (F,S) WE (or any BUS ADM 32X/42X)	3 cr.
[]	10.	BUS ADM 490 Strategic Decision Analysis (capstone) (F,S)	3 cr.
[]	III.	REQUIRED HUMAN RESOURCE EMPHASIS COURSES (four)	12 credits
[]	1.	BUS ADM 362 Human Resource Management (F,S)	3 cr.
[]	2.	BUS ADM 460 Human Resource Development (S) WE	3 cr.
[]	3.	BUS ADM 462 Seminar in Human Resource Management (S)	3 cr.
[]	4.	BUS ADM 467 Compensation and Benefits (F)	3 cr.
[]	IV.	REQUIRED MINOR	18 credits

All Business Administration students must choose a minor other than Business Administration or International Business. Recommended minors include: Accounting, Communication Processes, Economics, Psychology, Information Science, Humanistic Studies or any foreign language. Others of your choice are also accepted.

* Denotes a "Gateway Course" -- Refer to page 8 for more information.

Consult with your Business Administration--Management advisor for appropriate substitutions for any of the listed courses.

BUSINESS ADMINISTRATION MAJOR

MARKETING EMPHASIS

[] Check when completed

[]	I.	REQUIRED SUPPORTING COURSES (six)	18-19 credits
[]	1.	BUS ADM 215 Intro. to Business Stats (F,S) (or MATH 260 4cr.)	3 cr.
[]	2.	BUS ADM 217 Advanced Business Statistics (F,S)	3 cr.
[]	3.	BUS ADM 350 Business Computer Applications (F,S)	3 cr.
[]	4.	ECON 202 Macroeconomic Analysis (F,S)	3 cr.
[]	5.	ECON 203 Microeconomic Analysis (F,S)	3 cr.
[]	6.	ENG COMP 105 Expository Writing (F,S)**	3 cr.

(**Waived with ACT English score of 32 or higher)

[]	II.	REQUIRED CORE COURSES (ten)	31 credits
[]	1.	ACCTG 300 Introductory Accounting (F,S)	4 cr.
[]	2.	ACCTG 302 Managerial Accounting I (F,S)	3 cr.
[]	3.	ACCTG 305 Legal Environment of Business (F,S) *	3 cr.
[]	4.	BUS ADM 322 Introductory Marketing (F,S) *	3 cr.
[]	5.	BUS ADM 343 Corporation Finance (F,S) *	3 cr.
[]	6.	BUS ADM 347 Financial Markets and Institutions (F,S) (or any BUS ADM 34X/44X or BUS ADM 450)	3 cr.
[]	7.	BUS ADM 382 Introductory Management (F,S) *	3 cr.
[]	8.	BUS ADM 389 Organizational Behavior (F,S) (or any BUS ADM 38X/48X or BUS ADM 36X/46X or BUS ADM 472 ACCTG/BUS ADM 452)	3 cr.
[]	9.	BUS ADM 428 Consumer Behavior (F,S) WE	3 cr.
[]	10.	BUS ADM 490 Strategic Decision Analysis (capstone) (F,S)	3 cr.

[]	III.	REQUIRED MARKETING EMPHASIS COURSES (four)	12 credits
[]	1.	BUS ADM 421 International Marketing (F,S) WE OC	3 cr.
[]	2.	BUS ADM 424 Marketing Research (F)	3 cr.
[]	3.	Two of the following:	
[]	4.	BUS ADM 327 Selling and Sales Management (F) WE	3 cr.
		BUS ADM 423 Advertising (F,S)	3 cr.
		BUS ADM 426 Marketing Management (S)	3 cr.
		BUS ADM 427 Practicum in Marketing Research (S)	3 cr.

[]	IV.	REQUIRED MINOR	18 credits
-----	------------	-----------------------	-------------------

All Business Administration students must choose a minor other than Business Administration or International Business. Recommended minors include: Accounting, Communication Processes, Economics, Psychology, Information Science, Humanistic Studies or any foreign language. Others of your choice are also accepted.

* Denotes a "Gateway Course" -- Refer to page 8 for more information.

Consult with your Business Administration--Marketing advisor for appropriate substitutions for any of the listed courses.

BUSINESS ADMINISTRATION MINOR

[] Check when completed

[]	I.	SUPPORTING COURSES (five)	15-16 credits
[]	1. ⁽¹⁾	One of the following: BUS ADM 202 Business and its Environment (F) SS-1 BUS ADM 282 Personal Financial Planning (F,S)	3 cr. 3 cr.
[]	2.	One of the following: ACCTG 305 Legal Environment of Business (F,S) * BUS ADM 206 ⁽²⁾ Law and the Individual (F,S) SS-2	3 cr. 3 cr.
[]	3.	One of the following: BUS ADM 215 Introduction to Business Statistics (F,S) MATH 260 Introductory Statistics (F,S) COMM SCI 205 Social Science Statistics (F,S)	3 cr. 4 cr. 4 cr.
[]	4.	ECON 202 Macroeconomic Analysis (F,S)	3 cr.
[]	5.	ECON 203 Microeconomic Analysis (F,S)	3 cr.
[]	II.	UPPER DIVISION COURSES (four)	13 credits
[]	1.	ACCTG 300 Introductory Accounting (F,S)	4 cr.
[]	2.	BUS ADM 322 Introductory Marketing (F,S) *	3 cr.
[]	3.	BUS ADM 343 Corporation Finance (F,S) *	3 cr.
[]	4.	BUS ADM 382 Introductory Management (F,S) *	3 cr.

⁽¹⁾ Upon degree completion, requirement of BUS ADM 202 or BUS ADM 282 is waived for students obtaining an Accounting major.

⁽²⁾ BUS ADM 206 is valid for the Business Administration minor only. It cannot be applied to a Business Administration major.

* Denotes a "Gateway Course" -- Refer to page 8 for more information.

Consult with your Business Administration--Minor advisor for appropriate substitutions for any of the listed courses.

INTERNATIONAL BUSINESS MINOR

This Minor *will not* meet the outside minor requirements for Business Administration Majors. It will meet the outside minor requirements for Accounting Majors.

Check when completed

I. SUPPORTING COURSES (two) 6 credits

- | | | | | |
|--------------------------|----|----------|------------------------------|-------|
| <input type="checkbox"/> | 1. | ECON 202 | Macroeconomic Analysis (F,S) | 3 cr. |
| <input type="checkbox"/> | 2. | ECON 203 | Microeconomic Analysis (F,S) | 3 cr. |

II. UPPER DIVISION COURSES (four) 13 credits

- | | | | | |
|--------------------------|----|-------------|---------------------------------|-------|
| <input type="checkbox"/> | 1. | ACCTG 300 | Introductory Accounting (F,S) | 4 cr. |
| <input type="checkbox"/> | 2. | BUS ADM 322 | Introductory Marketing (F,S) * | 3 cr. |
| <input type="checkbox"/> | 3. | BUS ADM 343 | Corporation Finance (F,S) * | 3 cr. |
| <input type="checkbox"/> | 4. | BUS ADM 382 | Introductory Management (F,S) * | 3 cr. |

III. INTERNATIONAL COURSES (two) 6 credits

- | | | | | |
|--------------------------|----|------------------------------|---|-------|
| <input type="checkbox"/> | 1. | One of the following: | | |
| | | BUS ADM 445 | International Financial Management (S) | 3 cr. |
| | | BUS ADM 421 | International Marketing (F,S) | 3 cr. |
| | | ECON 403 | International Trade (S) | 3 cr. |
| <input type="checkbox"/> | 2. | One of the following: | | |
| | | GERMAN 420 | Business German (P: GERMAN 225, SE) | 3 cr. |
| | | FRENCH 367 | Business French (P: FRENCH 225, SO) | 3 cr. |
| | | SPANISH 359 | Cultures of the Americas (P: SPANISH 225, SO) | 3 cr. |

IV. LANGUAGE / STUDY ABROAD / INTERNSHIP REQUIREMENTS

- | | | |
|--------------------------|----|--|
| <input type="checkbox"/> | 1. | Two years of college-level language courses or equivalent competency. |
| <input type="checkbox"/> | 2. | International internship or participation in a study abroad program.
(Approved internships arranged through Business Administration, Modern Languages or International Education Office.) |

* Denotes a "Gateway Course" -- Refer to page 8 for more information.

The Major and Minor in ACCOUNTING

(disciplinary)

Both the major and minor in Accounting are disciplinary. "Disciplinary" means that all accounting students receive vigorous and thorough training in accounting. More than 90 percent of UW-Green Bay Accounting graduates typically find employment in their chosen career within six months of graduation. UW-Green Bay graduates are eligible to take professional accounting examinations, including the C.P.A. (Certified Public Accountant) once they have completed the state's mandated 150 credit hour requirement, C.M.A. (Certified Management Accountant), and C.I.A. (Certified Internal Auditing) examinations. Alumni surveys indicate that alumni perceive the Accounting program very favorably, their program of study prepared them extremely well for their careers, the quality of the Accounting faculty is "excellent" and they would definitely recommend the program to others. Recent surveys also suggest that well over 30 percent of the Accounting graduates pass all four parts of the C.P.A. exam during their first sitting; of those who take it a second time, 75 percent pass all four parts. These figures compare very favorably with the national averages, where the first time pass rate is approximately 20 percent.

These successes may be attributed to Accounting's contemporary and rigorous curriculum, a dedication to teaching excellence and to an emphasis on the skills basic to career advancement such as effective writing, speaking, quantitative analysis, computer proficiency, decision making and problem solving. In the Accounting program you gain both the in-depth accounting knowledge and the broad background in business needed to understand the role of accounting in the business world.

Accounting faculty are committed to serving the needs of business and society and to providing an outstanding learning environment. Upper-division classes frequently number fewer than 30 students, facilitating discussion and the opportunity to work closely with faculty. About one-third of the Accounting courses are offered late afternoons and evenings to accommodate employed students.

The Accounting program addresses contemporary accounting and business issues, including the role of accounting in continuous quality improvement, the implementation of computer technology, advances in accounting information systems and accounting ethics. These issues and more are addressed in specific classes and throughout the curriculum. Today's businesses require employees who are effective communicators and problem solvers with broad-based liberal educations. Accounting students take courses that develop their communication skills and they gain breadth through courses in the arts, humanities, social sciences and natural sciences.

Extensive opportunities are available to meet business professionals and to gain practical experience. Active student organizations provide opportunities to meet others with like interests and to develop contacts with businesses. Participation in the internship program is encouraged. Here students learn while working in an actual business setting. Many students continue working full-time for their internship sponsors upon graduation.

Since the major in Accounting is a disciplinary major the student must complete an interdisciplinary minor. **Students who complete the Accounting major automatically fulfill the requirements for the minor in Business Administration.** (The Business Administration minor requirement of BUS ADM 202 or BUS ADM 282 is waived for students obtaining an Accounting major.) Students who wish to minor in a program other than Business Administration should consult with their advisor.

CERTIFICATION EXAMINATION REQUIREMENTS

A completed degree in Accounting from UW-Green Bay qualifies you to sit for the C.I.A. and C.M.A. examinations. To sit for the C.P.A. examination, graduates must also satisfy the 150-credit requirement (see below).

For further C.P.A. examination information refer to: <http://www.cpa-exam.org>

150 CREDIT REQUIREMENT

Accounting graduates are required to have earned 150 college credits in order to be allowed to attempt the C.P.A. examination. The governor of Wisconsin signed this new requirement into law in early 1997. Accounting majors planning to sit for the C.P.A. examination should seek the advice of their advisor in order to plan a course of study that will most efficiently result in their meeting the 150-credit requirement.

The University of Wisconsin--Green Bay now offers a Masters of Management program. Completing this program will satisfy the 150-credit requirement. More information on this program can be found at <http://www.uwgb.edu/busadmin/management/>.

For additional information on the 150-credit requirement, please refer to the following web site:

<http://nxt.legis.state.wi.us/nxt/gateway.dll?f=templates&fn=default.htm&vid=WI:Default&d=codex&id=top>

Refer to ACCY 7: Education. Section 7.035

LICENSING REQUIREMENTS

For information on Wisconsin licensing requirements, please refer to the following web site:

<http://drl.wi.gov/prof/acct/def.htm>

GENERAL EDUCATION REQUIREMENTS

In addition to the requirements outlined on the following pages, everyone wishing to Major or Minor in Accounting is required to complete the general education requirements of the University of Wisconsin--Green Bay. These requirements are detailed in the University of Wisconsin--Green Bay Undergraduate Catalog and can also be found at <http://www.uwgb.edu/catalog/undrgrad/gened.htm>.

ACCOUNTING COURSE PRE-REQUISITES

Please be advised of the following Accounting course prerequisites that will be in effect beginning in the Spring, 2005 semester. All students attempting to enroll in the courses listed in the left column for Spring, 2005 or later, MUST meet the new pre-requisite listed in the right column.

<u>Course</u>	<u>New Pre-requisite</u>
ACCTG 301	Grade of "B" or better in ACCTG 300
ACCTG 312	Grade of "B" or better in ACCTG 302. REC: BUS ADM 215 or MATH 260, and BUS ADM 217
ACCTG 313	Grade of "B" or better in ACCTG 301. (effective Fall 2007)
ACCTG 314	Grade of "B" or better in ACCTG 301. (effective Fall 2007) REC: ACCTG 313.
ACCTG 316	Grade of "C" or better in ACCTG 301.
ACCTG 410	Grade of "C" or better in ACCTG 301. REC: ACCTG 305.
ACCTG 411	Grade of "B" or better in ACCTG 302.

These new prerequisites will be applied to all students, including transfer students, registering for the courses listed, regardless of the date that the prerequisite course was taken. For example: If you took ACCTG 301 in Fall 2003, and received a grade lower than "C", you will need to retake that course and earn a "C" or better in order to register for ACCTG 316, or 410. You will need to retake ACCTG 301 and earn a "B" or better in order to register for ACCTG 313, or 314. If you have already completed these courses you would NOT have to retake ACCTG 301.

ACCOUNTING INTERNSHIPS

Students interested in receiving credit for an accounting internship must have completed and passed ACCTG 301, Intermediate Accounting, and have an overall G.P.A. of at least 2.75. A maximum of six credits can be earned toward accounting internships. A student wishing to exceed this maximum must petition the unit chair for approval. Students may not receive internship credits for the same position in multiple semesters. As a general guideline, a 3-credit internship would be a position requiring a minimum of 10 hours of work per week. Additional internship information can be found at www.uwgb.edu/hussinb/internships.htm.

ACCOUNTING MAJOR

[] Check when completed

[]	I.	REQUIRED SUPPORTING COURSES (six)	18-19 credits
[]	1.	BUS ADM 215 Intro. to Business Stats (F,S) (or MATH 260 4cr.)	3 cr.
[]	2.	BUS ADM 217 Advanced Business Statistics (F,S)	3 cr.
[]	3.	BUS ADM 350 Business Computer Applications (F,S)	3 cr.
[]	4.	ECON 202 Macroeconomic Analysis (F,S)	3 cr.
[]	5.	ECON 203 Microeconomic Analysis (F,S)	3 cr.
[]	6.	ENG COMP 105 Expository Writing (F,S)**	3 cr.
		(**Waived with ACT English score of 32 or higher)	
[]	II.	REQUIRED CORE COURSES (twelve)	38 credits
[]	1.	ACCTG 300 Introductory Accounting (F,S)	4 cr.
[]	2.	ACCTG 302 Managerial Accounting I (F,S)	3 cr.
[]	3.	ACCTG 305 Legal Environment of Business (F,S) *	3 cr.
[]	4.	ACCTG 306 Business Law II (F,S)	4 cr.
[]	5.	ACCTG 452 Adv. Microcomputer Business Applies (F,S)	3 cr.
[]	6.	BUS ADM 322 Introductory Marketing (F,S) *	3 cr.
[]	7.	BUS ADM 343 Corporation Finance (F,S) *	3 cr.
[]	8.	BUS ADM 347 Financial Markets and Institutions (F,S)	3 cr.
[]	9.	BUS ADM 382 Introductory Management (F,S) *	3 cr.
[]	10.	BUS ADM 389 Organizational Behavior (F,S) (or any BUS ADM 38X/48X or BUS ADM 36X/46X or BUS ADM 472)	3 cr.
[]	11.	BUS ADM 428 Consumer Behavior (F,S) WE (or any BUS ADM 32X/42X)	3 cr.
[]	12.	BUS ADM 490 Strategic Decision Analysis (capstone) (F,S)	3 cr.
[]	III.	ACCOUNTING MAJOR COURSES (ten)	33 credits
[]	1.	ACCTG 301 Intermediate Accounting (F,S)	4 cr.
[]	2.	ACCTG 312 Managerial Accounting II (F)	3 cr.
[]	3.	ACCTG 313 Advanced Financial Accounting I (F)	3 cr.
[]	4.	ACCTG 314 Advanced Financial Accounting II (S)	3 cr.
[]	5.	ACCTG 316 Governmental and Nonprofit Accounting (F,S)	3 cr.
[]	6.	ACCTG 410 Intro. to Income Tax Theory and Practice (F)	3 cr.
[]	7.	ACCTG 411 Financial Information Systems (F)	4 cr.
[]	8.	ACCTG 412 Auditing Standards and Procedures (S) WE	4 cr.
[]	9.	ACCTG 414 Managerial Accounting III (S)	3 cr.
[]	10.	ACCTG 415 Advanced Income Tax Theory and Practice (S)	3 cr.
[]	IV.	HIGHLY RECOMMENDED ACCOUNTING COURSE (Not Required)	1 credit
[]		ACCTG 303 Seminar in Acctg Professionalism (F,S)	1 cr.

[] V. REQUIRED MINOR

Since the major in Accounting is a disciplinary major the student must complete an interdisciplinary minor. **Students who complete the Accounting major automatically fulfill the requirements for the minor in Business Administration.** (The Business Administration minor requirement of BUS ADM 202 or BUS ADM 282 is waived for students obtaining an Accounting major.) Students who wish to minor in a program other than Business Administration should consult with their advisor.

* Denotes a "Gateway Course" -- Refer to page 8 for more information.

Consult with your Accounting advisor for appropriate substitutions for any of the listed courses.

COURSE PLAN

The following is designed to assist you as you chart your academic progress toward an Accounting major.

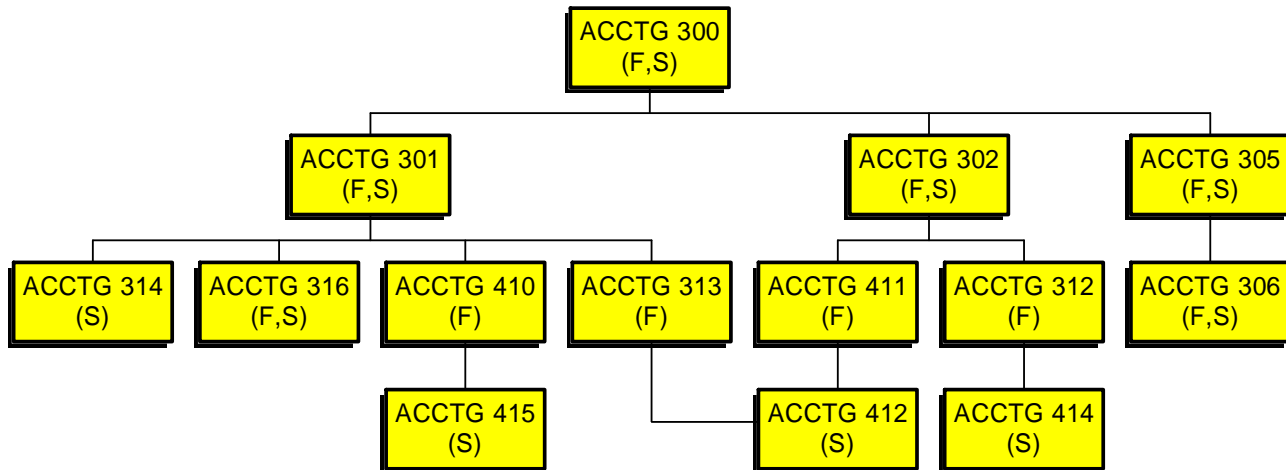

It is highly recommended that you also take the following one credit course at some point prior to graduation:

ACCTG 303 Seminar in Accounting Professionalism

1 cr.

Designed to familiarize prospective accounting majors with their profession. Topics will include various career paths in accounting, professional demeanor, and professional ethics.

P: ACCTG 300 (F,S)

ACCOUNTING MINOR

[] Check when completed

[] **I. SUPPORTING COURSES (two) 6 credits**

[] 1. **One of the following:**

ECON 202	Macroeconomic Analysis (F,S)	3 cr.
ECON 203	Microeconomic Analysis (F,S)	3 cr.

[] 2. ENG COMP105 Expository Writing (F,S)** 3 cr.
(* waived with ACT score of 32 or higher)

[] **II. UPPER DIVISION COURSES (seven) 23-24 credits**

Required (three)

[] 1.	ACCTG 300	Introductory Accounting (F,S)	4 cr.
[] 2.	ACCTG 301	Intermediate Accounting (F,S)	4 cr.
[] 3.	ACCTG 302	Managerial Accounting I (F,S)	3 cr.

[] 4. **One of the following:**

ACCTG 305	Legal Environment of Business (F,S) *	3 cr.
BUS ADM 322	Introductory Marketing (F,S) *	3 cr.
BUS ADM 382	Introductory Management (F,S) *	3 cr.

[] 5. **One of the following:**

ACCTG 312	Managerial Accounting II (F)	3 cr.
ACCTG 313	Advanced Financial Accounting I (F)	3 cr.

[] 6. **Two of the following:**

[] 7.	ACCTG 314	Advanced Financial Accounting II (S)	3 cr.
	ACCTG 316	Governmental and Nonprofit Accounting (F,S)	3 cr.
	ACCTG 410	Introduction to Income Tax Theory and Practice (F)	3 cr.
	ACCTG 411	Financial Information Systems (F)	4 cr.
	ACCTG 414	Managerial Accounting III (S)	3 cr.
	ACCTG 415	Advanced Income Tax Theory and Practice (S)	3 cr.

* Denotes a "Gateway Course" -- Refer to page 8 for more information.

Consult with your Accounting--Minor advisor for appropriate substitutions for any of the above courses.

The Associate of Arts and Science Degree Emphasis: BUSINESS ADMINISTRATION

(Students completing the following requirements will receive an “Associate of Arts and Sciences” degree.)

Requirements:

- A. Fulfillment of the “lower level” general education requirements for the baccalaureate degree.
 1. Unless an academic plan is already on file, requirements will be the most current general education requirements.
 2. Natural science must include the completion of a Laboratory Science course.
 3. “Lower level” includes breadth, other culture, ethnic studies and two courses in the writing emphasis requirement. (Upper level writing emphasis is not required.)
 4. At least one course must have an historical perspective. Historical perspectives satisfied through any H1, H2 or history course.
 5. At least one course must be taught from primary texts. The primary text requirement is satisfied in all H1, H2 or Engl H3 courses.
- B. Fulfillment of the math and English proficiency and competency requirements.
 1. These credits are not a part of the general education “breadth” requirements.
 2. Satisfied either through testing or completion of math 094 and English 093 and/or 100.
 3. Must complete two lower-level writing emphasis courses.
- C. Completion of 40 credits of “breadth” courses.
- D. Completion of the Business Administration area of emphasis which consists of the following:
 1. **Required foundation courses (three).** Designed to prepare the student to better comprehend various Business Administration courses. (Total 9 credits)
 - a. BUS ADM 215 Introduction to Business Statistics (3 cr.)
 - b. ECON 202 Macroeconomic Analysis (3 cr.)
 - c. ECON 203 Microeconomic Analysis (3 cr.)
 2. **Business Administration courses (five).** (Total 16 credits)
 - a. ACCTG 300 Introductory Accounting (4 cr.)
 - b. BUS ADM 322 Introductory Marketing * (3 cr.)
 - c. BUS ADM 343 Corporation Finance * (3 cr.)
 - d. BUS ADM 350 Business Computer Applications (3 cr.)
 - e. BUS ADM 382 Introductory Management * (3 cr.)

Note: A maximum of two additional Business Administration courses may be taken on consultation with an advisor.
- E. Earn 60 degree credits (AAS candidates are not eligible for honors programs.)
- F. Fifteen credits must be earned “in residence” and one half of the area of emphasis.
- G. Achieve a minimum grade point average of 2.0. (Note: The current grade point average requirement for admission to the Business Administration or Accounting major or minor is 2.5.)

* Denotes a “Gateway Course” -- Refer to page 8 for more information.

COURSE LIST

All courses are 3 credits unless otherwise indicated. Refer to course descriptions on the following pages for more information.

ACCOUNTING

ACCTG 300 Introductory Accounting (4 cr.)
 ACCTG 301 Intermediate Accounting (4 cr.)
 ACCTG 302 Managerial Accounting I
 ACCTG 303 Seminar in Acctg Professionalism (1 cr.)
 ACCTG 305 Legal Environment of Business *
 ACCTG 306 Business Law II (4 cr.)
 ACCTG 312 Managerial Accounting II
 ACCTG 313 Advanced Financial Accounting I
 ACCTG 314 Advanced Financial Accounting II
 ACCTG 316 Governmental and Nonprofit Accounting
 ACCTG 410 Intro. to Income Tax Theory and Practice
 ACCTG 411 Financial Information Systems (4 cr.)
 ACCTG 412 Auditing (4 cr.)
 ACCTG 414 Managerial Accounting III
 ACCTG 415 Advanced Inc Tax Theory and Practice
 ACCTG 452 Adv. Microcomputer Business Applics

FINANCE

BUS ADM 282 Personal Financial Planning
 BUS ADM 343 Corporation Finance *
 BUS ADM 344 Real Estate Principles
 BUS ADM 345 Risk Management & Insurance
 BUS ADM 347 Financial Markets and Institutions
 BUS ADM 442 Principles of Investments
 BUS ADM 445 International Financial Management
 BUS ADM 446 Advanced Corporation Finance
 BUS ADM 447 Advanced Investments
 BUS ADM 450 Bank Administration

GENERAL

BUS ADM 202 Business and Its Environment
 BUS ADM 206 Law and the Individual
 BUS ADM 490 Strategic Decision Analysis

MANAGEMENT

BUS ADM 362 Human Resource Management
 BUS ADM 382 Introductory Management *
 BUS ADM 384 Production/Operations Management
 BUS ADM 386 Field Project in Business Management
 BUS ADM 389 Organizational Behavior
 BUS ADM 460 Human Resource Development
 BUS ADM 462 Seminar in Human Resource Mgmt
 BUS ADM 467 Compensation and Benefits
 BUS ADM 472 Seminar in Leadership
 BUS ADM 480 Quality Management
 BUS ADM 482 Strategic Management
 BUS ADM 485 Managerial Economics
 BUS ADM 489 Organizational Theory

MARKETING

BUS ADM 322 Introductory Marketing *
 BUS ADM 327 Selling and Sales Management
 BUS ADM 421 International Marketing
 BUS ADM 423 Advertising
 BUS ADM 424 Marketing Research
 BUS ADM 426 Marketing Management
 BUS ADM 427 Practicum in Marketing Research
 BUS ADM 428 Consumer Behavior

QUANTITATIVE METHODS / MIS

BUS ADM 215 Introduction to Business Statistics
 BUS ADM 217 Advanced Business Statistics
 BUS ADM 350 Business Computer Applications
 BUS ADM 452 Adv. Microcomputer Business Applics

* Denotes a "Gateway Course" -- Refer to page 8 for more information.

COURSE DESCRIPTIONS

ACCOUNTING

ACCTG 300 Introductory Accounting

4 cr.

Principles, concepts and terminology of financial accounting including coverage of the measurement and recording of business income and transactions, current and long term assets, current and long term liabilities, corporate equity, statement of cash flows and financial statement analysis. Ethical considerations and analysis of company statements are integrated into the course. *P: sophomore status (F,S)*

ACCTG 301 Intermediate Accounting

4 cr.

Financial accounting theory, concepts, principles and procedures relating to the measurement and reporting of cash, receivables, inventories, fixed assets, intangibles, current liabilities, long-term debt, owner's equity; preparation and understanding of the balance sheet and income statement.

P: Grade of "B" or better in ACCTG 300 (F,S)

ACCTG 302 Managerial Accounting I

3 cr.

The use and understanding of management accounting information for planning, control, performance evaluation, decision making; product costing using traditional and activity-based costing techniques, just-in-time, cost-profit-volume relationships, budgeting, variance analysis, decentralization, relevant costing and ethics. *P: ACCTG 300 (F,S)*

ACCTG 303 Seminar in Accounting Professionalism

1 cr.

Designed to familiarize prospective accounting majors with their profession. Topics will include various career paths in accounting, professional demeanor, and professional ethics.

P: ACCTG 300 (F,S)

ACCTG 305 Legal Environment of Business (Gateway Course -- Refer to page 8)

3 cr.

Laws affecting business, emphasizing the Uniform Commercial Code. Introduction to law and the legal process, contracts, agency, property, landlord-tenant and real estate laws, sales and consumer protection laws, secured transactions, negotiable instruments, corporation and partnership law and estate and bankruptcy law. *P: (Minimum 36 earned credits and 2.5 GPA) or (BUS ADM or ACCTG or graduate classification) (F,S)*

ACCTG 306 Business Law II

4 cr.

Builds upon basic concepts covered in ACCTG 305 to further explore the legal implications of business transactions. Deals with federal and widely adopted uniform law. Topics include corporate law with an emphasis on traditional state law regulation of the corporation, trusts and wills, real property law, contracts for the sale of goods, debtor and creditor relations, and Commercial Paper. *P: ACCTG 305 (F,S)*

ACCTG 312 Managerial Accounting II

3 cr.

Expands and broadens the concepts and methods presented in ACCTG 302. Job order, process and joint product costing systems, ABC costing, standard costing, budgeting, JIT and cost estimation. Significant exposure to current issues and practices. Writing skills emphasized.

P: Grade of "B" or better in ACCTG 302 REC: (BUS ADM 215 or MATH 260 or COMM SCI 205) (F)

ACCTG 313 Advanced Financial Accounting I **3 cr.**

An expansion of Intermediate Financial Accounting. Specialized financial accounting topics, including price-level accounting, accounting changes, cash flow statement preparation, tax allocation, accounting for leases and pensions, special sales arrangements and partnerships; AICPA and FASB pronouncements affecting accounting practice.

P: Grade of "B" or better in ACCTG 301 (F)

ACCTG 314 Advanced Financial Accounting II **3 cr.**

Accounting for long-term investments; business combinations; preparation of consolidated financial statements; inter-company profit, debt and preferred stock issues; "earnings per share" calculations; accounting for branch operations and foreign operations.

P: Grade of "B" or better in ACCTG 301 REC: ACCTG 313 (S)

ACCTG 316 Governmental and Nonprofit Accounting **3 cr.**

Financial and managerial accounting concepts, theory and terminology related to state and local governmental entities and not for profit organizations including universities, health care organizations, voluntary health and welfare organizations and other not for profit entities. Analysis of actual municipal financial statements. Case studies, group work and/or class presentations emphasize application of theory to actual situations including ethical considerations.

P: ACCTG 300 and Grade of "C" or better in ACCTG 301 (F,S)

ACCTG 410 Introduction to Income Tax Theory and Practice **3 cr.**

Federal income taxation, especially tax rules and the determination of taxable income for individuals. Topics include: exclusions, deductions, passive activity losses, property transactions, nontaxable exchanges, capital gains and losses.

P: ACCTG 300 and Grade of "C" or better in ACCTG 301 REC: ACCTG 305 (F)

ACCTG 411 Financial Information Systems **4 cr.**

Principles of systems design, emphasizing organizational structure; internal control; flow charts and the impact of people on systems studies; systems requirements of the procedural areas of accounting systems, such as cash, purchasing, inventory management, sales, and billing.

P: Grade of "B" or better in ACCTG 302 (F)

ACCTG 412 Auditing Standards and Procedures **4 cr.**

Audit standards; professional ethics, legal liability of auditors; audit procedures relating to assets, liabilities, equity, revenue and expense accounts; review of computer applications in auditing, statistical sampling and internal auditing. *P: ACCTG 313 and ACCTG 411 WE (S)*

ACCTG 414 Managerial Accounting III **3 cr.**

Expands and broadens the concepts and methods presented in ACCTG 302 and ACCTG 312. Cost concepts for decision making, cost volume profit analysis, relevant costing, performance measurement, variable costing, transfer pricing, and decision making under uncertainty. Includes case analysis. Writing skills emphasized.

P: ACCTG 312 REC: (BUS ADM 215 or MATH 260 or COMM SCI 205) (S)

ACCTG 415 Advanced Income Tax Theory and Practice**3 cr.**

Advanced topics in federal taxation, with emphasis on the federal taxation of corporations, partnerships and exempt organizations. Estate and gift taxation and the income taxation of estates and trusts. *P: ACCTG 410 (S)*

ACCTG/BUS ADM 452 Advanced Microcomputer Business Applications**3 cr.**

Use of computer technology in management decision-making through a variety of decision-making models. Review and applications of management info systems, organizational concepts, spreadsheet software and modeling. *P: BUS ADM 350 and (BUS ADM 215 or MATH 260 or COMM SCI 205) (F,S)* **Note:** *Only ACCTG majors can enroll in the ACCTG 452 course listing. All others must enroll as BUS ADM 452.*

BUSINESS ADMINISTRATION

FINANCE COURSES

BUS ADM 282 Personal Financial Planning**3 cr.**

Exploration and functional analysis of consumers' financial needs and problems in our modern and complex society; learning to formulate financial goals, implement and monitor them through specific plans; financial functions such as budgeting, investing, financing, protecting and distributing wealth; philosophies and values of consumers; legal aspects of consumer rights. (F,S)

BUS ADM 343 Corporation Finance (Gateway Course -- Refer to page 8)**3 cr.**

Organization of basic financial management functions and principles for business; management of fixed and working capital; short-term and long-term financial planning through investment and financing decisions; domestic and international money and capital markets; ethical issues relating to business financial management. *P: (BUA or ACTG or graduate classification) or (36 earned credits and 2.5 GPA) and ACCTG 300 (F,S)*

BUS ADM 344 Real Estate Principles**3 cr.**

Nature of real estate ownership, importance of land contracts, title transfer and mortgage instruments; real estate valuation, finance and investment; impacts of taxation, insuring, marketing and laws affecting real estate. (Not intended to prepare students for real estate licensing examination.) *P: BUS ADM 343 (S)*

BUS ADM 345 Risk Management & Insurance**3 cr.**

Nature of risks, principal techniques of risk management and the bases for making decisions with respect to the management of personal and business risks. *P: BUS ADM 343 (F)*

BUS ADM 347 Financial Markets and Institutions**3 cr.**

Role of financial markets and institutions in forming and managing financial resources; examination and analysis of financial intermediation; organization and functions of the U.S. and international financial systems; structure and investment management strategies of specific financial institutions (such as banks, thrift, insurance and investment companies)

P: BUS ADM 343 (F,S)

BUS ADM 442 Principles of Investments**3 cr.**

Fundamental concepts, theories and techniques relating to investing; securities markets, investment vehicles and environments, economic, industry and security analyses, portfolio construction and management; active and passive investment strategies; global investment perspectives and their impacts on investors; blend of facts and theories relating to traditional and modern portfolio approaches; ethics in investment decisions; applied computer-assisted investment decisions.

P: BUS ADM 343 and (BUS ADM 215 or MATH 260 or COMM SCI 205) WE (F,S)

BUS ADM 445 International Financial Management**3 cr.**

Conceptual framework and applications of financial management decisions of multinational firms in a global setting; survey of the international financial environment; determinants of international portfolio and direct investment capital flows; assessment and management of impacts of foreign exchange and hedging strategies; impacts of international factors on capital budgeting and financial structure decisions; multinational money and capital markets; taxation of international business. *P: BUS ADM 343 REC: BUS ADM 442 (S)*

BUS ADM 446 Advanced Corporation Finance**3 cr.**

Short- and long-term financial decisions under risk and uncertainty; financial analysis, planning and control; in-depth coverage of theories and applications of capital structure, cost of capital, dividend policies; working capital management; long-term financing decisions; valuation of mergers and acquisitions; international capital budgeting.

P: BUS ADM 343 REC: BUS ADM 347 and BUS ADM 442 (F,S)

BUS ADM 447 Advanced Investments**3 cr.**

In-depth coverage of theories and applications of portfolio construction, analysis, and management of investment portfolios under the context of efficient and inefficient market hypotheses; computer models for portfolio construction and management; fundamental techniques in selection, analysis and management of stocks and bonds; reducing investment risk inherent in asset selection and management through the use of financial derivatives; techniques for measuring investment performance; global investment decisions. *P: BUS ADM 442 (F)*

BUS ADM 450 Bank Administration**3 cr.**

Commercial banking theories and practices from a financial management perspective; operations, administration, overall asset-liability management of commercial banks, including bank services, credit and loan pricing and analysis, investment portfolio problems, profitability, cost control and capital budgeting and analysis; implications of deregulation or re-regulation on the financial industry. *P: BUS ADM 347 REC: BUS ADM 442 (F)*

GENERAL COURSES

BUS ADM 202 Business and Its Environment

3 cr.

The major components of the business enterprise and its resources, competitive and regulatory environments; pricing, profit, finance planning, controls, ethics, environmental impact, social responsibility and other important concepts; environmental issues that challenge the business leader. (F) SS-1

BUS ADM 206 Law and the Individual

3 cr.

The American legal system; its principles, processes, language, ethics and laws from the viewpoint of the individual, including family, personal injury, property, consumer, privacy, probate and administrative laws. (F,S) SS-2

BUS ADM 490 Strategic Decision Analysis

3 cr.

In this capstone course for the Accounting and Business Administration majors, students are provided with a learning experience that draws on the conceptual, analytical, and interpersonal concepts and skills developed throughout the course of study. Students participate in a cross-functional, community-of-practice environment designed to enhance holistic issue resolution.

A grade of "C" or better is required to fulfill program requirements.

P: (major in BUS ADM or ACCTG) and (85 earned credits) and all of the following: (ACCTG 302, ECON 202, BUS ADM 322, BUS ADM 343, BUS ADM 350, BUS ADM 382) (F,S)

MANAGEMENT COURSES

BUS ADM 362 Human Resource Management

3 cr.

Personnel management: human resource planning, recruitment, selection, training, motivation, fringe benefits, salary and wages, labor relations and performance evaluation.

P: BUS ADM 382 (F,S)

BUS ADM 382 Introductory Management (Gateway Course -- Refer to page 8)

3 cr.

The realities of management in contemporary situations, emphasizing the functional approach; understanding the management environment; knowledge required by managers to function effectively and adjust to rapid changes. *P: [(BUA or ACTG or graduate classification) or (36 earned credits and 2.5 GPA) and (BUS ADM 215 or MATH 260 or COMM SCI205)] OR [(major in Interd Stu or Nursing) and ECON 152] (F,S)*

BUS ADM 384 Production/Operations Management

3 cr.

The management of physical and human resources in the production and operation functions for producing goods or providing services in manufacturing and processing enterprises.

P: BUS ADM 382 (S)

BUS ADM 386 Field Project in Business Management

3 cr.

Students are afforded the opportunity to work with an operating business throughout a semester. Individual and/or teams of students conduct applied problem solving research, formulate potential solutions, and present those solutions to the business.

P: BUS ADM 382 (F)

BUS ADM 389 Organizational Behavior

3 cr.

A micro organizational behavior course examining motivation, leadership, job satisfaction, learning, group dynamics and stress in the organizational setting.

P: BUS ADM 382 (F,S)

BUS ADM 460 Human Resource Development

3 cr.

This seminar focuses on the primary functions of human resource development--training and development, career development and organizational development. Activities and processes to assist an organization in becoming a learning organization are addressed.

P: BUS ADM 362 WE (S)

BUS ADM 462 Seminar in Human Resource Management

3 cr.

Analysis of human resource problems and issues and their translation into corporate policies; urban, cultural and legal realities in human resource matters; decisions affecting the development and management of human resource policies.

P: BUS ADM 362 (S)

BUS ADM 467 Compensation and Benefits Planning**3 cr.**

Theories of compensation and work motivation and their impact on various reward systems and the rationale for decisions affecting the selection of benefits. *P: BUS ADM 362 (F)*

BUS ADM 472 Seminar in Leadership**3 cr.**

The course examines contemporary ideas of leadership and issues leaders will face in guiding the organization of the future. The topic is addressed from the perspective of skills and abilities that can be acquired and applied by the student. Theoretical concepts are tied into practice through a course project in the University or the community. The course is structured in a seminar format with an emphasis on discussion. *P: BUS ADM 382 WE (F,S)*

BUS ADM 482 Strategic Management**3 cr.**

The course focuses on the formulation, selection and implementation of business strategies through assessment of organizational performance; competitive, market and industry analysis; development of strategic positions and identification of strategic opportunities. Students practice strategic thinking for a cross-section of business types from small, closely held, to corporate, publicly held, multiple business enterprises. The concepts and ideas of the course are explored through the analysis of case studies. *P: BUS ADM 382 (F,S)*

BUS ADM 485 Managerial Economics**3 cr.**

Applications of the basic theoretical tools of micro- and macro-economic analysis to the problems of business management, including such topics as demand, production, costs, pricing and forecasting as well as current economic issues such as environmental policies and regulations.

P: ECON 202 and ECON 203 and BUS ADM 382 (S)

BUS ADM 489 Organizational Theory**3 cr.**

A macro organizational behavior course examining organizational environments, structure, power and politics, conflict, innovation, technology and culture in the organizational setting.

P: BUS ADM 382 WE (F,S)

MARKETING COURSES

- BUS ADM 322 Introductory Marketing** (Gateway Course -- Refer to page 8) **3 cr.**
The marketing system and the managerial techniques used to market goods, services and organizations. Relationships between marketing activities and economic, political and social institutions; understanding consumer behavior; product, price, promotion and distribution decisions.
P: (BUA or ACTG or graduate classification) or (36 earned credits and 2.5 GPA) and ECON 203 (F,S)
- BUS ADM 327 Selling and Sales Management** **3 cr.**
Principles and techniques of successful selling that lead to a mutually profitable relationship between salesperson and customer. The nature and scope of sales management; selecting, training and directing sales personnel; importance of customer satisfaction; relationship of company philosophy to the sales force; fundamentals of communication processes.
P: BUS ADM 322 WE (F)
- BUS ADM 421 International Marketing** **3 cr.**
This course is designed to help students explore the global market via the disciplines of economics, cultural studies, geography, history, languages, jurisprudence, demographics, politics and many others. The opportunities and the threats that emanate from the global marketplace are highlighted and the need for an international "marketing" approach on the part of individuals and institutions is emphasized. *P: BUS ADM 322 WE World Culture (F,S)*
- BUS ADM 423 Advertising** **3 cr.**
Developing and executing advertising campaigns; how these campaigns fit into the total marketing mix; social, legal and economic considerations and constraints involved in the advertising campaign planning process. *P: BUS ADM 322 (F,S)*
- BUS ADM 424 Marketing Research** **3 cr.**
Techniques of obtaining and analyzing information about marketing problems; obtaining and interpreting data from primary and secondary sources for marketing decisions. Development of target market determination plans to test the feasibility and relevance of a proposed new small business or the expansion of an existing enterprise.
P: BUS ADM 322 and (BUS ADM 215 or MATH 260 or COMM SCI 205) (F)
- BUS ADM 426 Marketing Management** **3 cr.**
Advanced level course in marketing. Strategic interrelationships, development of analytical techniques and abilities and decision making in marketing. *P: BUS ADM 322 (S)*
- BUS ADM 427 Practicum in Marketing Research** **3 cr.**
Provides students with an opportunity to apply their knowledge of marketing research in hands-on fashion. Students will be doing comprehensive marketing research projects on behalf of area businesses. *P: BUS ADM 424 (S)*
- BUS ADM 428 Consumer Behavior** **3 cr.**
Theories of buyer behavior, including ultimate and industrial customers and their implications for marketing management. *P: BUS ADM 322 WE (F,S)*

QUANTITATIVE METHODS / MIS COURSES

BUS ADM 215 Introduction to Business Statistics

3 cr.

This course starts from the beginning principles of probability and statistics, and progresses to cover many business statistics applications. Topics included: a definition of business statistics, describing sets of measurements, probability, random variables and probability distributions, two useful discrete probability distributions, estimation, hypotheses testing, inferences from small samples, and other topics as time permits. Credit will not be granted for both BUS ADM 215 and (COMM SCI 205 or MATH 260) *P: MATH 101 or math placement of MATH 101/260 or greater (F,S)*

BUS ADM 217 Advanced Business Statistics

3 cr.

A treatment of advanced topics in statistics applied to a wide variety of business problems. Topics include analysis of variance, linear regression, correlation, multiple linear regression, elements of time series analysis, forecasting based on time series models, quality control techniques, survey sampling, analysis of enumerative data, non-parametric statistical methods and decision analysis. Practical business examples are used to illustrate and apply the advanced statistical techniques. Computer applications are included.

P: BUS ADM 215 or MATH 260 or COMM SCI 205 (F,S)

BUS ADM 350 Business Computer Applications

3 cr.

Business Computer Applications is designed to give students hands-on experience with popular software applications. The course also covers current introductory topics in computing such as computer software & hardware, internet, network security, databases, and ethics in IS among others. *P: sophomore status (F,S)*

ACCTG/BUS ADM 452 Advanced Microcomputer Business Applications

3 cr.

Use of computer technology in management decision-making using Microsoft Excel. Review and application of managerial decision-making models.

P: BUS ADM 350 and (BUS ADM 215 or COMM SCI 205 or MATH 260) (F,S)

Professional Programs in Business

FACULTY AND STAFF

Pat Albers , Lecturer (Finance)-----	458	465-2768
Kelly Anklam , Operations Manager-----	460T	465-2006
Lucy Arendt , Assistant Professor (Management) -----	460H	465-2817
Gaurav Bansal , Assistant Professor (MIS/Statistics) -----	460C	465-2216
Fran Baugnet , University Services Associate -----	460	465-2495
Gary Christens , Lecturer (Accounting)-----	454	465-2466
William Conley , Professor (Statistics)-----	460P	465-2499
James Doering , Associate Professor (Accounting/Law) -----	470G	465-2347
Robert Geimer , Lecturer (Law)-----	452	465-2778
Brent Hussin , Senior Lecturer (Management Information Systems)-----	460L	465-2575
Ernie Johnson , Lecturer (Management)-----	452	465-2778
Ken Knauf , Lecturer (Finance, Statistics)-----	460B	465-2004
Michael Knight , Assistant Professor (Management) -----	460D	465-2313
Bernd Kupka , Assistant Professor (Management/Human Resources)-----	460E	465-2496
William Lepley , Associate Professor (Finance), Assistant Chair, Business Admin-----	460R	465-2044
James Loebl , Assistant Professor (Accounting) -----	460A	465-2141
Donald McCartney , Senior Lecturer (Marketing)-----	460J	465-2520
Larry McGregor , Lecturer (Management)-----	456	465-2353
Steven Muzatko , Associate Professor (Accounting), Accounting Chairperson-----	460K	465-2578
Robert Nagy , Associate Professor (Finance)-----	460Q	465-2386
David Radosevich , Associate Professor (Management)-----	460F	465-2434
Sampath Ranganathan , Assistant Professor (Marketing) -----	460I	465-2484
Meir Russ , Associate Professor (Management) -----	460G	465-2757
Marilyn Sgrillo , Associate Professor (Accounting) and Business Admin Chairperson-----	460S	465-2762
Ann Selk , Senior Lecturer (Accounting)-----	470F	465-2756
Peter Smith , Associate Professor (Marketing) -----	460N	465-2509
Dan Spielmann , Lecturer (Law/Real Estate) -----	CL805E	465-5025
Barb Swanson , University Services Associate -----	460	465-2051
Mussie Teclezion , Visiting Assistant Professor (Finance) -----	454	465-2466
Cynthia Vopal , Lecturer (Law)-----	452	465-2778
David Yeghiaian , Lecturer (Management/Marketing) -----	460B	465-2004

Business Administration Phone: 465-2051
E-mail: busadmin@uwgb.edu

Fax: 465-2660
Office: WH460