



6.4. Exhibit

An exhibit is a three-dimensional physical and visual representation of your historical argument, research, and interpretation of your topic's significance in history.

<p>D1.</p>	<p>EXHIBIT ELEMENTS</p> <ul style="list-style-type: none"> ▶ Your analysis must be clear and evident to the viewer in the exhibit itself. Do not rely on supplemental material or media devices to deliver your message as judges may not have time to view them. ▶ Your argument must be supported with, but not overwhelmed by, visual and textual evidence. ▶ Your exhibit must conform to all general and category rules. ▶ Your exhibit must not include takeaway items for judges or others.
<p>D2.</p>	<p>SIZE REQUIREMENTS</p> <ul style="list-style-type: none"> ▶ The overall size of your exhibit when displayed for judging must be no larger than 40 inches wide, 30 inches deep, and 72 inches high. ▶ Circular or rotating exhibits or those meant to be viewed from all sides must be no more than 30 inches in diameter or diagonal. See Figure 6 (p. 32) for illustration. ▶ Measurement of the exhibit does not include the table on which it rests. ▶ Measurement does include any base that you create, any table drapes that you provide, and supplemental materials placed on the table.

<p>D3.</p>	<p>WORD LIMIT</p> <ul style="list-style-type: none"> ▶ A 500-word limit applies to all words that you write. Each word or number counts as one word. See Figure 3 (p. 21) for instructions about counting words. ▶ The following words DO count: <ul style="list-style-type: none"> > Text that you write, including titles, subtitles, captions, graphs, timelines, media devices, or supplemental materials (e.g., photo albums, scrapbooks) ▶ Words in the following DO NOT count: <ul style="list-style-type: none"> > Primary or secondary materials or quotes included on your exhibit or in media or supplemental materials > Source credits <p>NOTES:</p> <ol style="list-style-type: none"> 1. Rely on your own analysis, primary sources, and visuals to tell your story. Use caution when deciding on the length and quantity of quotes, primary or secondary. See Student Voice (Section 4.4, p. 12). 2. Extensive supplemental material is inappropriate. Oral history transcripts, correspondence between you and interview subjects, questionnaires, and other primary or secondary material used as sources for your exhibit should be cited in your bibliography, but not attached to your bibliography or exhibit.
<p>D4.</p>	<p>MEDIA DEVICES</p> <ul style="list-style-type: none"> ▶ If used, media devices or electronics in an exhibit must not run for more than a total of two minutes and must not loop continuously. ▶ Any media devices must not include dramatic or narrative student involvement. ▶ Judges must be able to control media devices by using clearly visible and accessible on/off and volume controls. ▶ Media devices must fit within the size and word limits of the exhibit. ▶ Anything that links externally, such as QR codes, is prohibited.
<p>D5.</p>	<p>CREDITING SOURCES</p> <ul style="list-style-type: none"> ▶ All quotes and visual sources (e.g., photographs, paintings, charts, graphs) must be credited on the exhibit and cited in the annotated bibliography. ▶ Source credits do not count toward the word total. ▶ See nhd.org/annotated-bibliography for more information and an example of a source credit.
<p>D6.</p>	<p>REQUIRED WRITTEN MATERIALS</p> <ul style="list-style-type: none"> ▶ Provide your required written materials for judging. ▶ Bring additional copies to contests, as they may be needed. ▶ Refer to your Contest Coordinator for submission instructions.

FIGURE 6. EXHIBIT SIZE LIMIT ILLUSTRATION

Drawings are not to scale and do not illustrate all possible exhibit shapes.

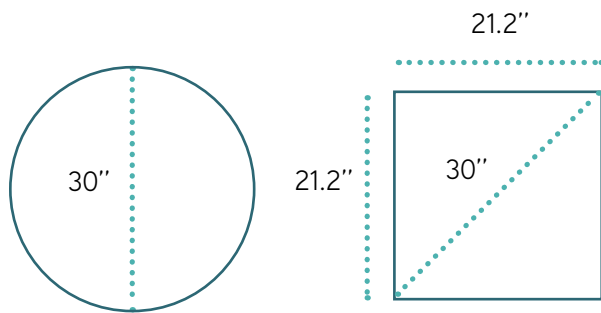

Top View of Circular or Rotating Exhibits or Those Meant to be Viewed from All Sides

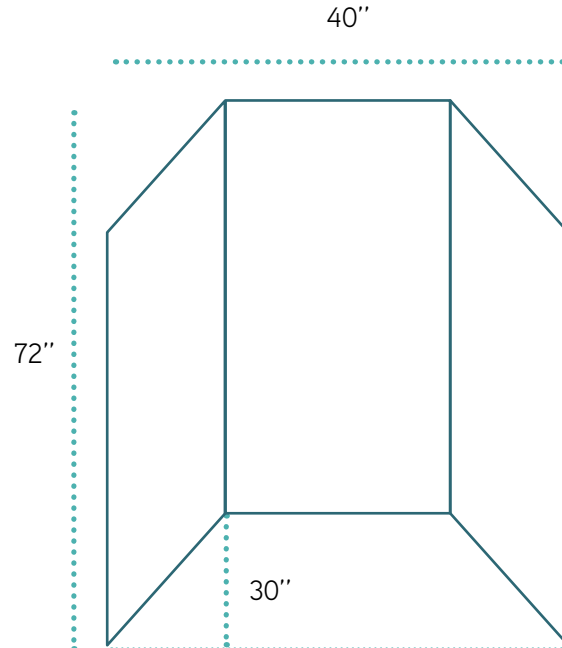

Front View of Stationary Exhibit with Maximum Dimensions