

---

# Database Processing

## 11<sup>th</sup> Edition

David M. Kroenke and David J. Auer

---

### APPENDIX D

Data Structures for Database Processing



**Executive Editor:** Bob Horan  
**Editorial Director:** Sally Yagan  
**AVP/Editor-in-Chief:** Eric Svendsen  
**Assistant Editor:** Kelly Loftus  
**Director of Marketing:** Patrice Lumumba Jones  
**Senior Marketing Manager:** Anne Fahlgren  
**Marketing Assistant:** Susan Osterlitz  
**Senior Managing Editor:** Judy Leale  
**Production Project Manager:** Kelly Warsak  
**Senior Operations Supervisor:** Arnold Vila  
**Operations Specialist:** Ilene Kahn  
**Senior Art Director:** Janet Slowik

**Design Director:** Christy Mahon  
**Cover and Interior Design:** Karen Quigley  
**Manager, Rights and Permissions:** Charles Morris  
**Manager, Cover Visual Research & Permissions:** Karen Sanatar  
**Cover Illustration:** Stockbyte/Veer/Corbis  
**Media Director:** Lisa Rinaldi  
**Lead Media Project Manager:** Denise Vaughn  
**Full-Service Project Management:** Jennifer Welsch/BookMasters, Inc.  
**Composition:** Integra Software Services  
**Printer/Binder:** Quebecor World-Versailles  
**Cover Printer:** Lehigh-Phoenix Color/Hagerstown  
**Text Font:** 10/12 Kepler MM

Credits and acknowledgments borrowed from other sources and reproduced, with permission, in this textbook appear on appropriate page within text.

Microsoft® and Windows® are registered trademarks of the Microsoft Corporation in the U.S.A. and other countries. Screen shots and icons reprinted with permission from the Microsoft Corporation. This book is not sponsored or endorsed by or affiliated with the Microsoft Corporation.

MySQL®, the MySQL GUI Tools® (MySQL Query Brower® and MySQL Administrator®), the MySQL Command Line Client®, and MySQL Workbench® are registered trademarks of Sun Microsystems, Inc. in the U.S.A and other countries. Screenshots and icons reprinted with permission of Sun Microsystems, Inc. This book is not sponsored or endorsed by or affiliated with Sun Microsystems.

Eclipse® and The Eclipse PHP Development Tools (PDT) Project® are trademarks of the Eclipse Foundation, Inc. The Eclipse platform is copyright Eclipse copyright holders and others, 2000, 2007. Screenshots reprinted under the terms of the Eclipse Public License v1.0 available at [www.eclipse.org/legal/epl-v10.html](http://www.eclipse.org/legal/epl-v10.html). This book is not sponsored or endorsed by or affiliated with the Eclipse Foundation, Inc.

PHP is copyright The PHP Group 1999–2008, and is used under the terms of the PHP Public License v3.01 available at [http://www.php.net/license/3\\_01.txt](http://www.php.net/license/3_01.txt). This book is not sponsored or endorsed by or affiliated with The PHP Group.

Oracle is a registered trademark of Oracle Corporation and/or its affiliates. Other names may be trademarks of their respective owners.

**Copyright © 2010, 2006, 2004, 2000, 1998 Pearson Education, Inc., publishing as Prentice Hall, One Lake Street, Upper Saddle River, New Jersey 07458.** All rights reserved. Manufactured in the United States of America. This publication is protected by Copyright, and permission should be obtained from the publisher prior to any prohibited reproduction, storage in a retrieval system, or transmission in any form or by any means, electronic, mechanical, photocopying, recording, or likewise. To obtain permission(s) to use material from this work, please submit a written request to Pearson Education, Inc., Permissions Department, One Lake Street, Upper Saddle River, New Jersey 07458.

Many of the designations by manufacturers and seller to distinguish their products are claimed as trademarks. Where those designations appear in this book, and the publisher was aware of a trademark claim, the designations have been printed in initial caps or all caps.

#### Library of Congress Cataloging-in-Publication Data

Kroenke, David.

Database processing: fundamentals, design, and implementation/David M. Kroenke, David J. Auer.—11th ed.  
p. cm.

Includes bibliographical references and index.

ISBN 978-0-13-230267-8 (casebound : alk. paper)

1. Database management. I. Auer, David J. II. Title.

QA76.9.D3K7365 2009  
005.74—dc22

2009011144

10 9 8 7 6 5 4 3 2 1

**Prentice Hall**  
is an imprint of



[www.pearsonhighered.com](http://www.pearsonhighered.com)

ISBN 10: 0-13-230267-5  
ISBN 13: 978-0-13-230267-8

## Data Structures for Database Processing

### Chapter Objectives

- To define the term *data structures*.
- To define and illustrate the terms *flat file*, *sequential list*, *linked list*, and *index*.
- To define and illustrate B-tree multilevel indexes.
- To demonstrate how binary relationships are represented using trees, simple networks, and complex networks.
- To define and illustrate primary and secondary keys.
- To define and illustrate unique and nonunique secondary keys.

All operating systems provide data management services. These services, however, are generally not sufficient for the specialized needs of a DBMS. Therefore, to enhance performance, DBMS products build and maintain specialized data structures, which are the topic of this appendix.

We begin by discussing flat files and some of the problems that can occur when such files need to be processed in different orders. Then, we turn to three specialized data structures: sequential lists, linked lists, and indexes (or inverted lists). Next, we illustrate how each of three special structures—trees, simple networks, and complex networks—are represented using various data structures. Finally, we explore how to represent and process multiple keys.

Although a thorough knowledge of data structures is not required to use most DBMS products, this background is essential for database administrators and systems programmers working with a DBMS. Being familiar with the data structures also helps you evaluate and compare database products.

### Flat Files

A **flat file** is a file that has no repeating groups. Figure D-1(a) shows a flat file, and Figure D-1(b) shows a file that is not flat because of the repeating field *Item*. A flat file can be stored in any common file organization, such as sequential, indexed sequential, or direct. Flat files have been used for many years in commercial processing. They are usually processed in some predetermined order—for example, in an ascending sequence on a key field.

Enrollment Record

StudentNumber	ClassNumber	Semester
---------------	-------------	----------

Sample Data

200	70	2000S
100	30	2001F
300	20	2001F
200	30	2000S
300	70	2000S
100	20	2000S

(a) Flat File Invoice Record

Invoice Record

InvoiceNumber	Item(s)
---------------	---------

Sample Data

1000	10	20	30	40
1010	50			
1020	10	20	30	
1030	50	90		

(b) Nonflat File Invoice Record

Figure D-1

Examples of a Flat File and a Nonflat File Invoice Record

Processing Flat Files in Multiple Orders

Sometimes users may want to process flat files in ways that are not readily supported by the file organization. Consider, for example, the ENROLLMENT records shown in Figure D-1(a). To produce student schedules, they must be processed in StudentNumber sequence. But to produce class rosters, the records need to be processed in ClassNumber sequence. The records, of course, can be stored in only one physical sequence. For example, they can be in order on StudentNumber or on ClassNumber, but not on both at the same time. The traditional solution to the problem of processing records in different orders is to sort them in student order and process the student schedules and then sort the records in class order and produce class rosters.

For some applications, such as batch-mode systems, this solution is effective, although cumbersome. But suppose that both orders need to exist simultaneously because two concurrent users have different views of the ENROLLMENT records. What do we do then?

One solution is to create two copies of the ENROLLMENT file and sort them, as shown in Figure D-2. Because the data are listed in sequential order, this data structure is sometimes called a **sequential list**. Sequential lists can be readily stored as sequential files. This solution, however, is not generally done by DBMS products because sequentially reading a file is a slow process. Further, sequential files cannot be updated in the middle without rewriting the entire file. Also, maintaining several orders by keeping multiple copies of the same sequential list is usually not effective because the duplicated sequential list can create data integrity problems. Fortunately, other data structures allow us to process records in different orders and do not require the duplication of data. These data structures include *linked lists* and *indexes*.

A Note on Record Addressing

Usually, the DBMS creates large **physical records**, or **blocks**, on its direct access files. These records are used as containers for logical records. Typically, each physical record has many logical records. Here, we assume that each physical record is addressed by its **relative record number (RRN)**. Thus, a logical record might be assigned to physical record number 7, 77, or 10,000. The relative record number is thus the logical record's physical address. If each physical

Figure D-2

ENROLLMENT Data Stored as Sequential Lists

Student-Number	Class-Number	Semester
100	30	2001F
100	20	2000S
200	70	2000S
200	30	2000S
300	20	2001F
300	70	2000S

(a) Stored by StudentNumber

Student-Number	Class-Number	Semester
300	20	2001F
100	20	2000S
100	30	2001F
200	30	2000S
200	70	2000S
300	70	2000S

(b) Stored by ClassNumber

record has more than one logical record, the address must also specify where the logical record is within the physical record. Thus, the complete address for a logical record might be relative record number 77, byte location 100. This means the record begins in byte 100 of physical record 77.

To simplify the illustrations in this text, we assume that there is only one logical record per physical record, so we need not be concerned with byte offsets within physical records. Although this is unrealistic, it limits our discussion to the essential points.

### Maintaining Order with Linked Lists

**Linked lists** can be used to keep records in logical order that are not necessarily in physical order. To create a linked list, we add a field to each data record. The **link field** holds the address (in our illustrations, the relative record number) of the *next* record in logical sequence. For example, Figure D-3 shows the ENROLLMENT records expanded to include a linked list; this list maintains the records in StudentNumber order. Notice that the link for the numerically last student in the list is zero.

Figure D-4 shows ENROLLMENT records with two linked lists: One list maintains the StudentNumber order and the other list maintains the ClassNumber order. Two link fields have been added to the records, one for each list.

When insertions and deletions are made, linked lists have a great advantage over sequential lists. For example, to insert the ENROLLMENT record for Student 200 and Class 45, both of the lists shown in Figure D-2 would need to be rewritten. For the linked lists in Figure D-4, however, the new record could be added to the physical end of the list, and only the values of two link fields would need to be changed to place the new record in the correct sequences. These changes are shown in Figure D-5.

When a record is deleted from a sequential list, a gap is created. But in a linked list, a record can be deleted simply by changing the values of the link, or the **pointer fields**. In Figure D-6, the ENROLLMENT record for Student 200, Class 30, has been logically deleted. No other record points to its address, so it has been effectively removed from the chain, even though it still exists physically.

There are many variations of linked lists. We can make the list into a **circular list**, or **ring**, by changing the link of the last record from zero to the address of the first record in the list. Now we

**Figure D-3**  
ENROLLMENT Data in StudentNumber Order Using a Linked List

Relative Record Number	Student-Number	Class-Number	Semester	Link
1	200	70	2000S	4
2	100	30	2001F	6
3	300	20	2001F	5
4	200	30	2000S	3
5	300	70	2000S	0
6	100	20	2000S	1

Start of list = 2

**Figure D-4**  
ENROLLMENT Data in Two Orders Using a Linked List

Relative Record Number	Student-Number	Class-Number	Semester	Student Link	Class Link
1	200	70	2000S	4	5
2	100	30	2001F	6	1
3	300	20	2001F	5	4
4	200	30	2000S	3	2
5	300	70	2000S	0	0
6	100	20	2000S	1	3

Start of student list = 2  
Start of class list = 6

Figure D-5

ENROLLMENT Data After Inserting a New Record on Two Orders Using Linked Lists

Relative Record Number	Student-Number	Class-Number	Semester	Student Link	Class Link
1	200	70	2000S	4	5
2	100	30	2001F	6	7
3	300	20	2001F	5	4
4	200	30	2000S	7	2
5	300	70	2000S	0	0
6	100	20	2000S	1	3
7	200	45	2000S	3	1

Start of student list = 2  
Start of class list = 6

Figure D-6

ENROLLMENT Data After Deleting Student 200, Class 30 (in Two Orders Using Linked Lists)

Relative Record Number	Student-Number	Class-Number	Semester	Student Link	Class Link
1	200	70	2000S	7	5
2	100	30	2001F	6	7
3	300	20	2001F	5	2
4	200	30	2000S	7	2
5	300	70	2000S	0	0
6	100	20	2000S	1	3
7	200	45	2000S	3	1

Start of student list = 2  
Start of class list = 6

can reach every item in the list starting at any item in the list. Figure D-7(a) shows a circular list for the StudentNumber order. A **two-way linked list** has links in both directions. In Figure D-7(b), a two-way linked list has been created for both ascending and descending student orders.

Figure D-7

ENROLLMENT Data Sorted by StudentNumber Using

Relative Record Number	Student-Number	Class-Number	Semester	Link
1	200	70	2000S	4
2	100	30	2001F	6
3	300	20	2001F	5
4	200	30	2000S	3
5	300	70	2000S	2
6	100	20	2000S	1

Start of list = 2  
(a) A Circular List

Relative Record Number	Student-Number	Class-Number	Semester	Ascending Link	Descending Link
1	200	70	2000S	4	6
2	100	30	2001F	6	0
3	300	20	2001F	5	4
4	200	30	2000S	3	1
5	300	70	2000S	0	3
6	100	20	2000S	1	2

Start of ascending list = 2  
Start of descending list = 5  
(b) A Two-Way Linked List

Records ordered using linked lists cannot be stored on a sequential file because some type of direct-access file organization is needed to use the link values. Thus, either indexed sequential or direct file organization is required for linked-list processing.

### Maintaining Order with Indexes

A logical record order can also be maintained using an **index**, or **inverted list**, as they are sometimes called. An index is simply a table that cross-references record addresses with some field value. For example, Figure D-8(a) shows the ENROLLMENT records stored in no particular order, and Figure D-8(b) shows an index on StudentNumber. In this index, the StudentNumbers are arranged in sequence, with each entry in the list pointing to a corresponding record in the original data.

As you can see, the index is simply a sorted list of StudentNumbers. To process ENROLLMENT sequentially on StudentNumber, we simply process the index sequentially, obtaining ENROLLMENT data by reading the records indicated by the pointers. Figure D-8(c) shows another index for ENROLLMENT—one that maintains ClassNumber order.

To use an index, the data to be ordered (here, ENROLLMENT) must reside on an indexed sequential or direct file, although the indexes can reside on any type of file. In practice, almost all DBMS products keep both the data and the indexes on direct files.

If you compare the linked list with the index, you will notice the essential difference between them. In a linked list, the pointers are stored along with the data. Each record contains a link field containing a pointer to the address of the next related record. But in an index, the pointers are stored in indexes, separate from the data. Thus, the data records themselves contain no pointers. Both techniques are used by commercial DBMS products.

### B-Trees

A special application of the concept of indexes, or inverted lists, is a **B-tree**, which is a multilevel index that allows both sequential and direct processing of data records. It also ensures a certain level of efficiency in processing because of the way that the indexes are structured.

A B-tree is an index that is made up of two parts: the sequence set and the index set. (These terms are used by IBM's VSAM file organization documentation. You may encounter other synonymous terms.) The **sequence set** is an index containing an entry for every record in the file. This index is in physical sequence, usually by primary key value. This arrangement allows sequential access to the data records, as follows: Process the sequence set in order, read the address of each record, and then read the record.

The **index set** is an index pointing to groups of entries in the sequence set index. This arrangement provides rapid direct access to records in the file, and it is the index set that makes B-trees unique.

An example of a B-tree appears in Figure D-9, and an occurrence of this structure can be seen in Figure D-10. Notice that the bottom row in Figure D-9, the sequence set, is simply an index. It contains an entry for every record in the file (although for brevity, both the data records and their addresses have been omitted). Also, notice that the sequence set entries are in groups

**Figure D-8**  
ENROLLMENT Data and Corresponding Indexes

Relative Record Number	Student-Number	Class-Number	Semester
1	200	70	2000S
2	100	30	2001F
3	300	20	2001F
4	200	30	2000S
5	300	70	2000S
6	100	20	2000S

(a) ENROLLMENT Data

Student-Number	Relative Record Number
100	2
100	6
200	1
200	4
300	3
300	5

(b) Index on StudentNumber

Class-Number	Relative Record Number
20	3
20	6
30	2
30	4
70	1
70	5

(c) Index on ClassNumber

**Figure D-9**

General Structure of a Simple B-Tree

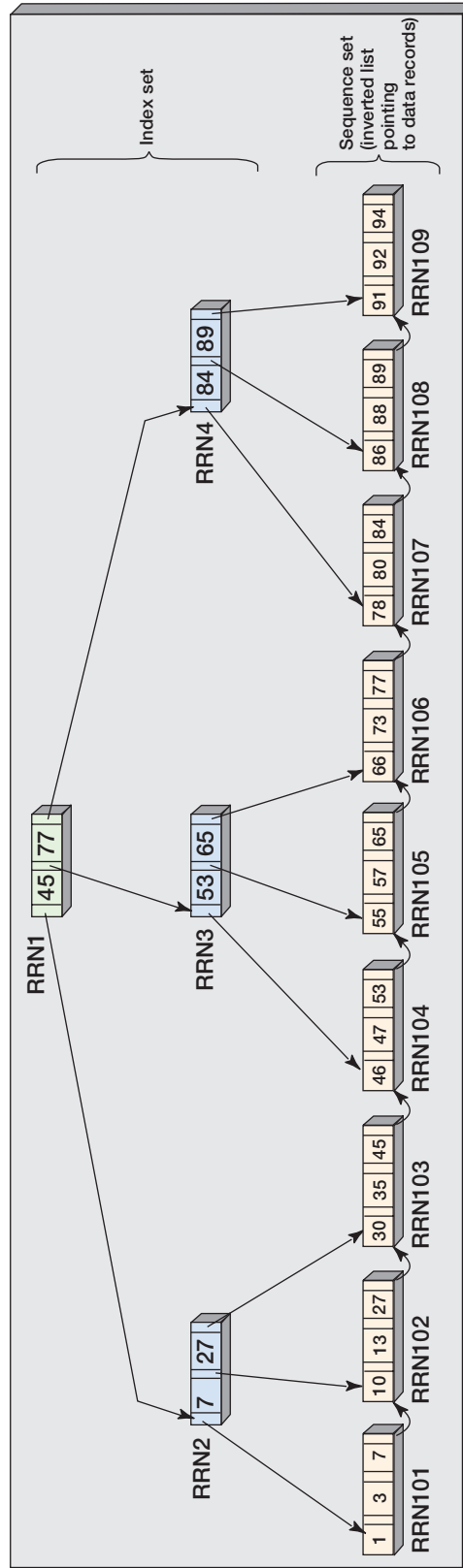

**Figure D-10**  
Occurrence of the B-Tree  
in Figure D-9

RRN	Link1	Value1	Link2	Value2	Link3
1	2	45	3	77	4
2	101	7	102	27	103
3	104	53	105	65	106
4	107	84	108	89	109

Index Set

	R1	Addr1	R2	Addr2	R3	Addr3	Link
101	1	Data or pointer	3	Data or pointer	7	Data or pointer	102
102	10	...	13	...	27	...	103
103	30	...	35	...	45	...	104
104	46	...	47	...	53	...	105
105	55	...	57	...	65	...	106
106	66	...	73	...	77	...	107
107	78	...	80	...	84	...	108
108	86	...	88	...	89	...	109
109	91	...	92	...	94	...	0

Sequence Set  
(Addresses of data records are omitted)

of three. The entries in each group are physically in sequence, and each group is chained to the next one by means of a linked list, as can be seen in Figure D-10.

Examine the index set in Figure D-9. The top entry contains two values: 45 and 77. By following the leftmost link (to RRN2), we can access all the records whose key field values are less than or equal to 45; by following the middle pointer (to RRN3) we can access all the records whose key field values are greater than 45 and less than or equal to 77; and by following the rightmost pointer (to RRN4) we can access all the records whose key field values are greater than 77.

Similarly, at the next level there are two values and three pointers in each index entry. Each time we drop to another level, we narrow our search for a particular record. For example, if we continue to follow the leftmost pointer from the top entry and then follow the rightmost pointer from there, we can access all the records whose key field value is greater than 27 and less than or equal to 45. We have eliminated all that were greater than 45 at the first level.

B-trees are, by definition, balanced. That is, all of the data records are exactly the same distance from the top entry in the index set. This aspect of B-trees ensures performance efficiency, although the algorithms for inserting and deleting records are more complex than those for ordinary trees (which can be unbalanced), because several index entries may need to be modified when records are added or deleted to keep all records the same distance from the top index entry.

### Summary of Data Structures

Figure D-11 summarizes the techniques for maintaining ordered flat files. Three supporting data structures are possible. Sequential lists can be used, but the data must be duplicated in order to maintain several orders. Because sequential lists are not used in database processing, we will not consider them further. Both linked lists and indexes can be used without data duplication. B-trees are special applications of indexes.

As shown in Figure D-11, sequential lists can be stored using any of three file organizations. In practice, however, they are usually kept on sequential files. In addition, although both linked

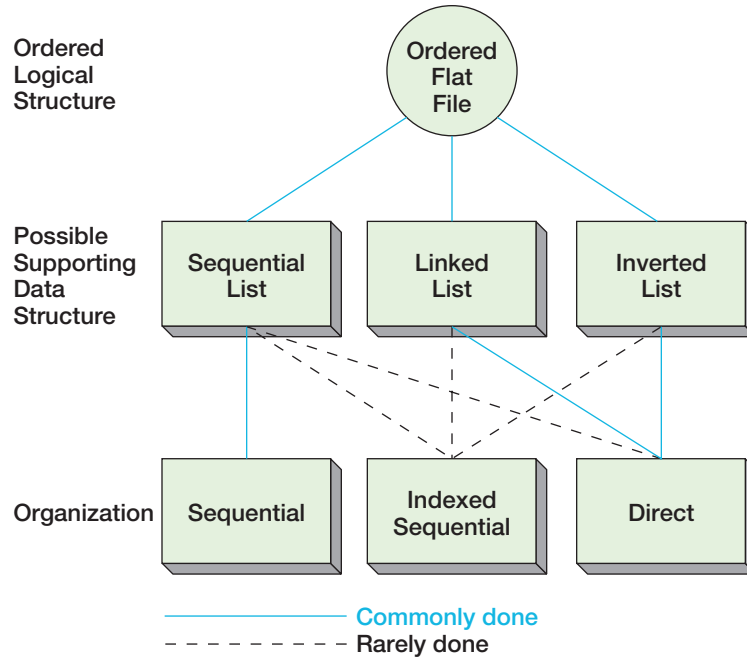

**Figure D-11**  
 Summary of Data Structures and Data Organizations Used for Order Flat Files

lists and indexes can be stored using either indexed sequential or direct files, DBMS products almost always store them on direct files.

## Representing Binary Relationships

In this section, we examine how each of the specialized record relationships—trees, simple networks, and complex networks—can be represented using linked lists and indexes.

### Review of Record Relationships

Records can be related in three ways. A **tree** relationship has one or more one-to-many relationships, but each child record has at most one parent. The occurrence of faculty data shown in Figure D-12 illustrates a tree. There are several 1:N relationships, but any child record has only one parent, as shown in Figure D-13.

A **simple network** is a collection of records and the 1:N relationships among them. What distinguishes a simple network from a tree is the fact that in a simple network, a child can have

**Figure D-12**  
 Occurrence of a Faculty Member Record

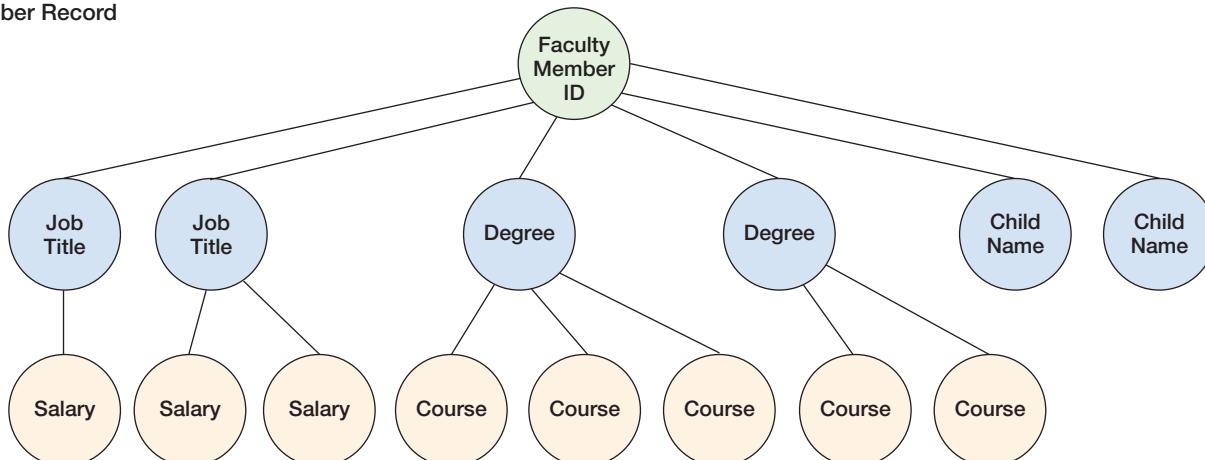

Figure D-13  
Schematic of a Faculty Member Tree Structure

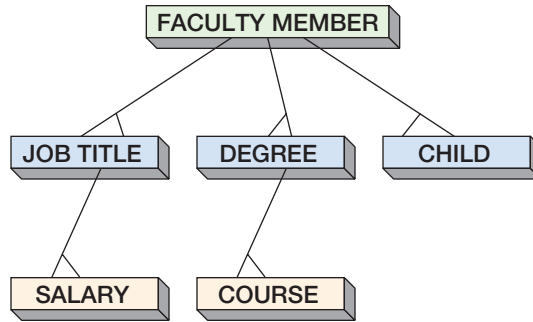
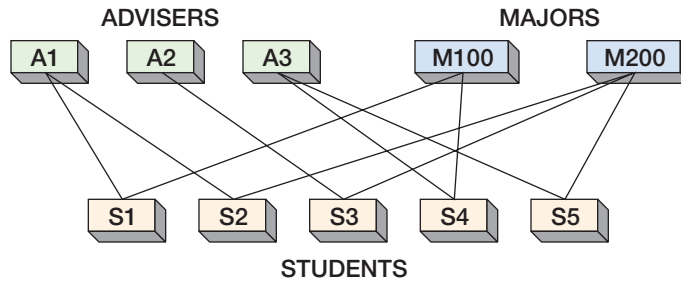

Figure D-14  
Occurrence of a Simple Network



more than one parent as long as the parents are different record types. The occurrence of a simple network of students, advisers, and major fields of study shown in Figure D-14 is represented schematically in Figure D-15.

A **complex network** is also a collection of records and relationships, but the relationships are many-to-many instead of one-to-many. The relationship between students and classes is a complex network. An occurrence of this relationship can be seen in Figure D-16, and the general schematic is in Figure D-17.

Figure D-15  
General Structure of a Simple Network

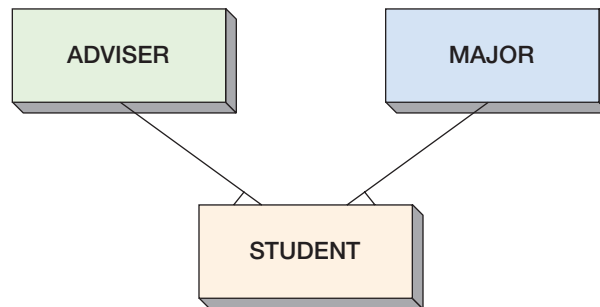
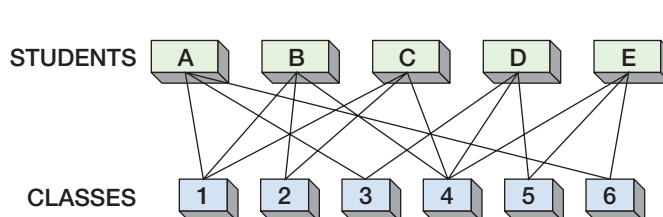
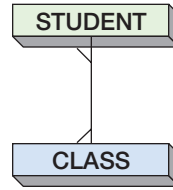

Figure D-16  
Occurrence of a Complex Network



**Figure D-17**  
Schematic of a Complex Network



We saw earlier that we can use linked lists and indexes to process records in orders different from the one in which they are physically stored. We can also use those same data structures to store and process the relationships among records.

### Representing Trees

We can use sequential lists, linked lists, and indexes to represent trees. When using sequential lists, we duplicate many data; and furthermore, sequential lists are not used by DBMS products to represent trees. Therefore, we describe only linked lists and indexes.

#### Linked-List Representation of Trees

Figure D-18 shows a tree structure in which the VENDOR records are parents and the INVOICE records are children. Figure D-19 shows two occurrences of this structure, and all of the VENDOR and INVOICE records have been written to a direct access file in Figure D-20. VENDOR AA is in relative record number 1 (RRN1), and VENDOR BB is in relative record number 2. The INVOICE records have been stored in subsequent records, as illustrated. Note that these records are not stored in any particular order and that they do not need to be.

Our problem is that we cannot tell which invoices belong to which vendors from this file. To solve this problem with a linked list, we add a pointer field to every record. In this field, we store the address of some other related record. For example, we place in VENDOR AA's link field the address of the first invoice belonging to it. This is RRN7, which is Invoice 110. Then, we

**Figure D-18**  
Sample Tree Relating VENDOR and INVOICE Records

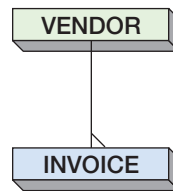

**Figure D-19**  
Two Occurrences of the VENDOR-INVOICE Tree

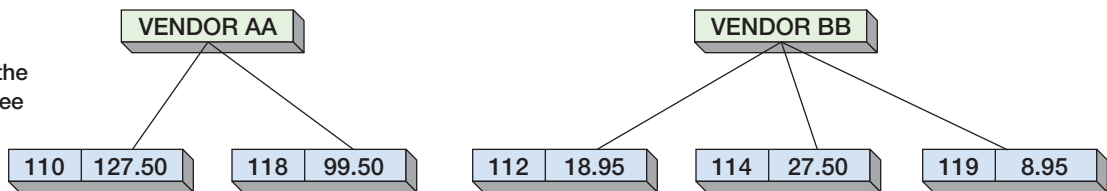

**Figure D-20**  
File Representation of the Trees in Figure D-19

Record Number	Record Contents	
1	VENDOR AA	
2	VENDOR BB	
3	118	99.50
4	119	8.95
5	112	18.95
6	114	27.50
7	110	127.50

**Figure D-21**  
Three Occurrences  
Represented by Linked Lists

Relative Record Number	Record Contents	Link Field
1	VENDOR AA	7
2	VENDOR BB	5
3	118 99.50	0
4	119 8.95	0
5	112 18.95	6
6	114 27.50	4
7	110 127.50	3

make Invoice 110 point to the next invoice belonging to VENDOR AA, in this case RRN3. This slot holds Invoice 118. To indicate that there are no more children in the chain, we insert a 0 in the link field for RRN3.

This technique is shown in Figure D-21. If you examine the figure, you will see that a similar set of links has been used to represent the relationship between VENDOR BB and its invoices.

The structure in Figure D-21 is much easier to modify than is a sequential list of the records. For example, suppose that we add a new invoice, say number 111, to VENDOR AA. To do this, we just add the record to the file and insert it into the linked list. Physically, the record can be placed anywhere. But where should it be placed logically? Usually, the application will have a requirement; for example, children are to be kept in ascending order on invoice number. If so, we need to make Invoice 110 point to Invoice 111 (at RRN8), and we need to make Invoice 111, the new invoice, point to Invoice 118 (at RRN3). This modification is shown in Figure D-22.

Similarly, deleting an invoice is easy. If Invoice 114 is deleted, we simply modify the pointer in the invoice that is now pointing to Invoice 114. In this case, it is Invoice 112 at RRN5. We give Invoice 112 the pointer that Invoice 114 had before deletion. In this way, Invoice 112 points to Invoice 119, as shown in Figure D-23. We have effectively cut one link out of the chain and welded together the ones it once connected.

**Figure D-22**  
Inserting Invoice 111 into  
the File in Figure D-21

Relative Record Number	Record Contents	Link Field
1	VENDOR AA	7
2	VENDOR BB	5
3	118 99.50	0
4	119 8.95	0
5	112 18.95	6
6	114 27.50	4
7	110 127.50	8
8	111 19.95	3

← Inserted Record

**Figure D-23**  
Deleting Invoice 114 into  
the File in Figure D-22

Relative Record Number	Record Contents	Link Field
1	VENDOR AA	7
2	VENDOR BB	5
3	118 99.50	0
4	119 8.95	0
5	112 18.95	4
6	114 27.50	4
7	110 127.50	8
8	111 19.95	3

← Deleted Record

Figure D-24  
Index Representation of the  
VENDOR-INVOICE  
Relationship

Parent Record	Child Record
1	7
1	3
2	5
2	6
2	4

### Index Representation of Trees

A tree structure can readily be represented using indexes. The technique is to store each one-to-many relationship as an index. These lists are then used to match parents and children.

Using the VENDOR and INVOICE records in Figure D-19, we see that VENDOR AA (in RRN1) owns INVOICES 110 (RRN7) and 118 (RRN3). Thus, RRN1 is the parent of RRN7 and RRN3. We can represent this fact with the index in Figure D-24. The list simply associates a parent's address with the addresses of each of its children.

If the tree has several 1:N relationships, several indexes will be required—one for each relationship. For example, for the structure in Figure D-13, five indexes are needed.

### Representing Simple Networks

As with trees, simple networks can also be represented using linked lists and indexes.

#### Linked-List Representation of Simple Networks

Consider the simple network shown in Figure D-25. It is a simple network because all of the relationships are 1:N, and the SHIPMENT records have two parents of different types. Each SHIPMENT has a CUSTOMER parent and a TRUCK parent. The relationship between CUSTOMER and SHIPMENT is 1:N because a customer can have several shipments, and the relationship from TRUCK to SHIPMENT is 1:N because one truck can hold many shipments (assuming that the shipments are small enough to fit in one truck or less). An occurrence of this network is shown in Figure D-26.

To represent this simple network with linked lists, we need to establish one set of pointers for each 1:N relationship. In this example, that means one set of pointers to connect CUSTOMERs with their SHIPMENTs and another set of pointers to connect TRUCKs with their

Figure D-25  
Simple Network Structure

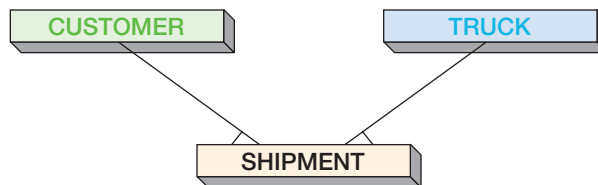
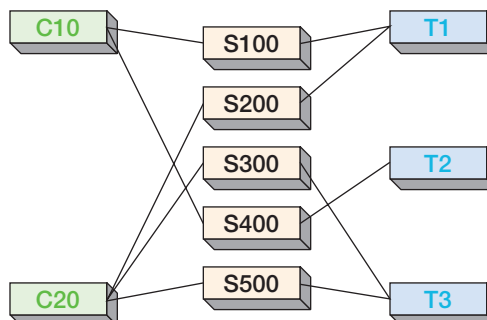

Figure D-26  
Occurrence of the Simple  
Network in Figure D-25



Relative Record Number	Record Contents	Link Fields	
1	C10	6	
2	C20	7	
3	T1		6
4	T2		9
5	T3		8
6	S100	9	7
7	S200	8	0
8	S300	10	10
9	S400	0	0
10	S500	0	0

↑ CUSTOMER Links      ↑ TRUCK Links

**Figure D-27**  
Representation of a Simple Network with Linked Lists

SHIPMENTS. Thus, a CUSTOMER record will contain one pointer (to the first SHIPMENT it owns); a TRUCK record will contain one pointer (to the first SHIPMENT it owns); and a SHIPMENT record will have two pointers, one for the next SHIPMENT owned by the same CUSTOMER and one for the next SHIPMENT owned by the same TRUCK. This scheme is illustrated in Figure D-27.

A simple network has at least two 1:N relationships, each of which can be represented using an index, as we explained in our discussion of trees. For example, consider the simple network shown in Figure D-25. It has two 1:N relationships, one between TRUCK and SHIPMENT and one between CUSTOMER and SHIPMENT. We can store each of these relationships in an index. Figure D-28 shows the two indexes needed to represent the example in Figure D-26. Assume that the records are located in the same positions as shown in Figure D-27.

### Representing Complex Networks

Complex networks can be represented in a variety of ways. They can be decomposed into trees or simple networks, and these simpler structures can then be represented using one of the techniques just described. Alternatively, they can be represented directly using indexes. Linked lists are not used by any DBMS product to represent complex networks directly. In practice, complex networks are nearly always decomposed into simpler structures, so we consider only those representations using decomposition.

A common approach to representing complex networks is to reduce them to simple networks and then to represent the simple networks with linked lists or indexes. Note, however, that a complex network involves a relationship between two records, whereas a simple network involves relationships among three records. Thus, in order to decompose a complex network into a simple one, we need to create a third record type.

The record that is created when a complex network is decomposed into a simple one is called an **intersection record**. Consider the StudentClass complex network. An intersection record contains a unique key from a STUDENT record and a unique key from a corresponding

Customer Record	Shipment Record	Truck Record	Shipment Record
1	6	3	6
1	9	3	7
2	7	4	9
2	8	5	8
2	10	5	10

**Figure D-28**  
Representation of a Simple Network with Index

**Figure D-29**  
Decomposition of Complex Network into Simple Network

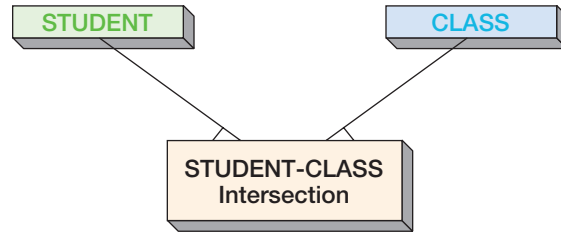

CLASS record. It will contain no other application data, although it might contain link fields. The general structure of this relationship is shown in Figure D-29. Assuming that the record names are unique (such as S1, S2, and C1), an instance of the STUDENT-CLASS relationship is illustrated in Figure D-30.

Notice that the relationship between STUDENT and the intersection record and that between CLASS and the intersection record both are 1:N. Thus, we have created a simple network that can now be represented with the linked-list or index techniques shown earlier. A file of this occurrence using the linked-list technique is shown in Figure D-31.

### Summary of Relationship Representations

Figure D-32 summarizes the representations of record relationships. Trees can be represented using sequential lists (although we did not discuss this approach), linked lists, or indexes. Sequential lists are not used in DBMS products. A simple network can be decomposed into trees and then represented or it can be represented directly using either linked lists or indexes. Finally, a complex network can be decomposed into a tree or a simple network (using intersection records) or it can be represented directly using indexes.

**Figure D-30**  
Instance of STUDENT-CLASS Relationship Showing Intersection Records

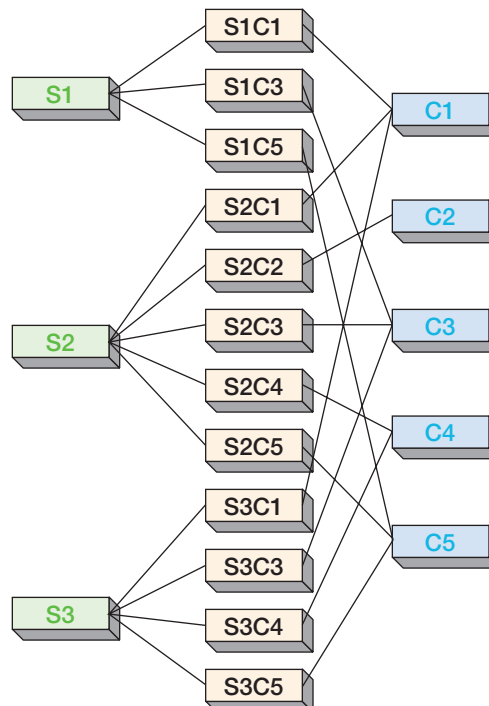

Relative Record Number	Record Contents	Link Fields	
1	S1	9	
2	S2	12	
3	S3	17	
4	C1		9
5	C2		13
6	C3		10
7	C4		15
8	C5		11
9	S1C1	10	12
10	S1C3	11	14
11	S1C5	0	16
12	S2C1	13	17
13	S2C2	14	0
14	S2C3	15	18
15	S2C4	16	19
16	S2C5	0	20
17	S3C1	18	0
18	S3C3	19	0
19	S3C4	20	0
20	S3C5	0	0

STUDENT Links      CLASS Links

**Figure D-31**  
Occurrence of Network in Figure D-30

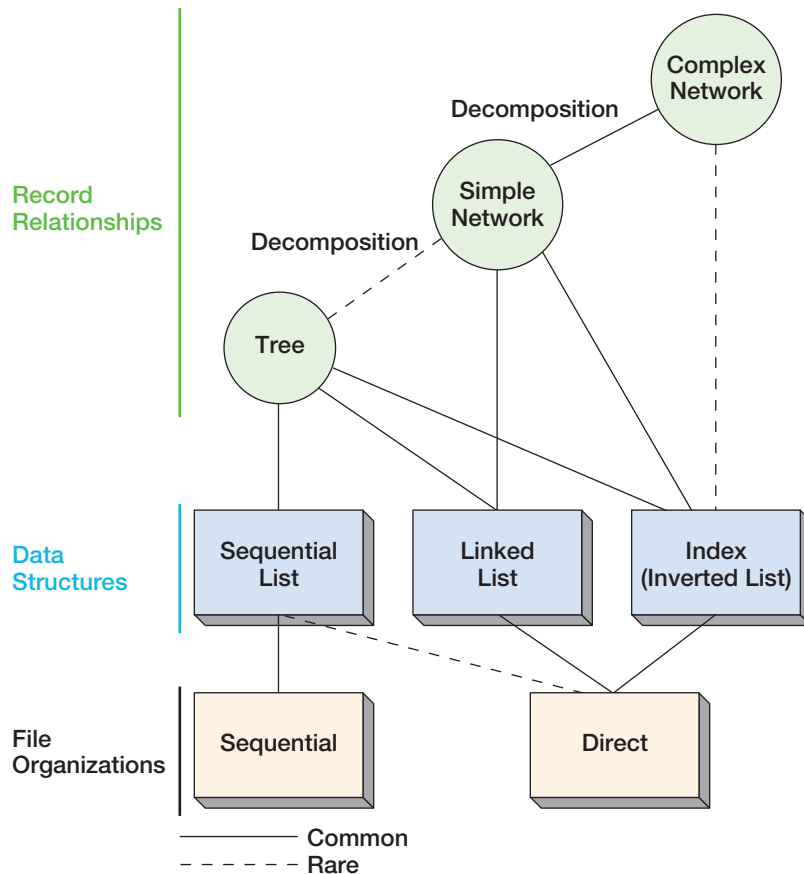

**Figure D-32**  
Record Representations, Data Structures, and File Organizations

## Secondary-Key Representations

In many cases, the word **key** indicates a field (or fields) whose value uniquely identifies a record. This is usually called the **primary key**. Sometimes, however, applications need to access and process records by means of a **secondary key**, one that is different from the primary key. Secondary keys may be a **unique secondary key** (such as a professor’s name) or a **nonunique secondary key** (such as a customer’s zip code). In this section, we use the term **set** to refer to all records having the same value of a nonunique secondary key; for example, a set of records having zip code 98040.

Both linked lists and indexes are used to represent secondary keys, but linked lists are practical only for nonunique keys. Indexes, however, can be used for both unique and nonunique key representations.

### Linked-List Representation of Secondary Keys

Consider the example of CUSTOMER records shown in Figure D-33. The primary key is AccountNumber, and there is a secondary key on CreditLimit. Possible CreditLimit values are 500, 700, and 1000. Thus, there will be a set of records for the limit of 500, a set for 700, and a set for 1000.

To represent this key using linked lists, we add a link field to the CUSTOMER records. Inside this link field, we create a linked list for each set of records. Figure D-34 shows a database of 11 customers; but, for brevity, only AccountNumber and CreditLimit are shown. A link field has been attached to the records. Assume that one database record occupies one physical record on a direct file using relative record addressing.

Three **pointers** need to be established so that we know where to begin each linked list. These pointers, called **heads**, are stored separately from the data. The head of the \$500 linked list is RRN1. Record 1 links to record 2, which in turn links to record 7. Record 7 has a zero in the link position, indicating that it is the end of the list. Consequently, the \$500 credit limit set consists of records 1, 2, and 7. Similarly, the \$700 set contains records 3, 5, and 10; the \$1000 set contains relative records 4, 6, 8, 9, and 11.

The \$1000-set linked list can be used to answer a query such as “How many accounts in the \$1000 set have a balance in excess of 900?” In this way, only those records in the \$1000 set need to be read from the file and examined. Although the advantage of this approach is not readily apparent in this small example, suppose that there are 100,000 CUSTOMER records, and only 100 of them are in the \$1000 set. If there is no linked list, all 100,000 records must be examined;

Figure D-33  
CUSTOMER Record



Figure D-34  
Representing the CreditLimit  
Secondary Key Using a  
Linked List

Relative Record Number	Link	Account-Number	Credit-Limit	Other Data
1	2	101	500	
2	7	301	500	
3	5	203	700	
4	6	004	1000	
5	10	204	700	
6	8	905	1000	
7	0	705	500	
8	9	207	1000	
9	11	309	1000	
10	0	409	700	
11	0	210	1000	

HEAD-500 = 1  
HEAD-700 = 3  
HEAD-1000 = 4

but with the linked list, only 100 records need to be examined—namely, the ones in the \$1000 set. Using the linked list, therefore, saves 99,900 reads.

Using linked lists is not an effective technique for every secondary-key application. In particular, if the records are processed nonsequentially in a set, linked lists are inefficient. For example, if it is often necessary to find the 10th or 120th or  $n^{\text{th}}$  record in the \$500 CreditLimit set, processing will be slow. Linked lists are inefficient for direct access.

In addition, if the application requires that secondary keys be created or destroyed dynamically, the linked-list approach is undesirable. Whenever a new key is created, a link field must be added to every record, which often requires reorganizing the database, which is a time-consuming and expensive process.

Finally, if the secondary keys are unique, each list will have a length of one, and a separate linked list will exist for every record in the database. Because this situation is unworkable, linked lists cannot be used for unique keys. For example, suppose that the CUSTOMER records contain another unique field, say, Social Security Number. If we attempt to represent this unique secondary key using a linked list, every Social Security Number will be a separate linked list. Furthermore, each linked list will have just one item in it: the single record having the indicated Social Security Number.

### Index Representation of Secondary Keys

A second technique for representing secondary keys uses an index; one is established for each secondary key. The approach varies, depending on whether the key values are unique or nonunique.

#### Unique Secondary Keys

Suppose that the CUSTOMER records in Figure D-33 contain Social Security Numbers (SSN) as well as the fields shown. To provide key access to the CUSTOMER records using SSN, we simply build an index on the SSN field. Sample CUSTOMER data are shown in Figure D-35(a), and a corresponding index is illustrated in Figure D-35(b). This index uses relative record numbers as addresses. It is possible to use AccountNumbers instead, in which case the DBMS locates the desired SSN in the index, obtains the matching AccountNumber, and then converts the AccountNumber to a relative record address.

#### Nonunique Secondary Keys

Indexes can also be used to represent nonunique secondary keys, but because each set of related records can contain an unknown number of members the entries in the index are of variable length. For example, Figure D-36 shows the index for the CreditLimit sets for the CUSTOMER data. The \$500 set and the \$700 set both have three members, so there are three account numbers in each entry. The \$1000 set has five members, so there are five account numbers in that entry.

**Figure D-35**  
Representing a Unique Secondary Key with Indexes  
(a) Sample CUSTOMER Data with SSN  
(b) Index for SSN Secondary Key

Relative Record Number	Account-Number	Credit-Limit	Social Security Number (SSN)
1	101	500	000-01-0001
2	301	500	000-01-0005
3	203	700	000-01-0009
4	004	1000	000-01-0003

(a)

SSN	Relative Record Number
000-01-0001	1
000-01-0003	4
000-01-0005	2
000-01-0009	3

(b)

**Figure D-36**  
Index for the CreditLimit Key in Figure D-33

CreditLimit	AccountNumber				
500	101	301	705		
700	203	204	409		
1000	004	905	207	309	210

**Figure D-37**  
Values and Occurrence  
Tables for the CreditLimit  
Key in Figure D-33

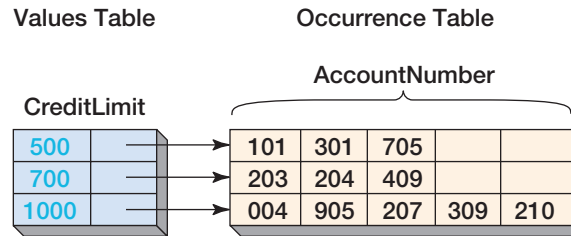

In reality, representing and processing nonunique secondary keys are complex tasks. Several different schemes are used by commercial DBMS products. One common method uses a values table and an occurrence table. Each values table entry consists of two fields, the first of which has a key value. For the CUSTOMER CreditLimit key, the values are 500, 700, and 1000.

The second field of the values table entry is a pointer into the occurrence table. The occurrence table contains record addresses, and those having a common value in the secondary-key field appear together in the table. Figure D-37 shows the values and occurrence tables for the CreditLimit key.

To locate records having a given value of the secondary key, the values table is searched for the desired value. After the given key value is located in the values table, the pointer is followed to the occurrence table to obtain the addresses of those records having that key value. These addresses are then used to obtain the desired records.

When a new record is inserted into the file, the DBMS must modify the indexes for each secondary-key field. For nonunique keys, it must make sure that the new record key value is in the values table; if it is, it adds the new record address to the appropriate entry in the occurrence table. If it is not, it must insert new entries in the values and occurrence tables. When a record is deleted, its address must be removed from the occurrence table. If no addresses remain in the occurrence table entry, the corresponding values table entry must also be deleted.

When the secondary-key field of a record is modified, the record address must be removed from one occurrence table entry and inserted into another. If the modification is a new value for the key, an entry must be added to the values table.

The index approach to representing secondary keys overcomes the objections to the linked-list approach. Direct processing of sets is possible. For example, the third record in a set can be retrieved without processing the first or second one. Also, it is possible to dynamically create and delete secondary keys. No changes are made in the records themselves; the DBMS merely creates additional values and occurrence tables. Finally, unique keys can be processed efficiently.

The disadvantages of the index approach are that it requires more file space (the tables use more overhead than the pointers do) and that the DBMS programming task is more complex.

Note that the *application programming* task is not necessarily any more or less difficult—but it is more complex to write DBMS software that processes indexes than it is to write software that processes linked lists. Finally, modifications are usually processed more slowly because of the reading and writing actions required to access and maintain the values in the occurrence tables.

## Key Terms

blocks  
B-tree  
circular list  
complex network  
flat file  
Head  
Index  
index set

intersection record  
inverted list  
key  
link field  
linked list  
nonunique secondary key  
physical records  
pointer

pointer field	sequential list
primary key	set
relative record number (RRN)	simple network
ring	tree
secondary key	two-way linked list
sequence set	unique secondary key

## Review Questions

- D.1** Define a flat file. Give an example (other than one in this text) of a flat file and an example of a file that is not flat.
- D.2** Show how sequential lists can be used to maintain the file in Review Question D.1 in two different orders simultaneously.
- D.3** Show how linked lists can be used to maintain the file in Review Question D.1 in two different orders simultaneously.
- D.4** Show how inverted lists can be used to maintain the file in Review Question D.1 in two different orders simultaneously.
- D.5** Define *tree*. Offer an example tree structure.
- D.6** Give an occurrence of the tree in Review Question D.5.
- D.7** Represent the occurrence in Review Question D.6 using linked lists.
- D.8** Represent the occurrence in Review Question D.6 using indexes.
- D.9** Define a simple network and give an example structure.
- D.10** Give an occurrence of the simple network in Review Question D.9.
- D.11** Represent the occurrence in Review Question D.10 using linked lists.
- D.12** Represent the occurrence in Review Question D.10 using indexes.
- D.13** Define complex network. Offer an example of a complex network structure.
- D.14** Give an occurrence of the complex network in Review Question D.13.
- D.15** Decompose the complex network in Review Question D.14 into a simple network and represent an occurrence of it using indexes.
- D.16** Explain the difference between primary and secondary keys.
- D.17** Explain the difference between unique and nonunique keys.
- D.18** Define a file containing a unique secondary key. Represent an occurrence of that file using an index on the secondary key.
- D.19** Define a nonunique secondary key for the file in Review Question D.18. Represent an occurrence of that file using a linked list on the secondary key.
- D.20** Perform the same task as in Review Question D.19, but use an index to represent the secondary key.
- D.21** Develop an algorithm to produce a report listing the IDs of students enrolled in each class using the linked-list structure in Figure D-4.
- D.22** Develop an algorithm to insert records into the structure in Figure D-4. The resulting structure should resemble the one shown in Figure D-5.
- D.23** Develop an algorithm to produce a report listing the IDs of students enrolled in each class using the index structure shown in Figures D-8(a), D-8(b), and D-8(c).

- D.24** Develop an algorithm to insert a record into the structure shown in Figure D-8(a). Be sure to modify both of the associated indexes shown in Figure D-8(b) and D-8(c).
- D.25** Develop an algorithm to delete a record from the structure shown in Figure D-34, which shows a secondary key represented with a linked list. If all records for one of the credit-limit categories (say, \$1000) are deleted, should the associated head pointer also be deleted? Why or why not?
- D.26** Develop an algorithm to insert a record into the structure shown in Figure D-34. Suppose that the new record has a credit-limit value different from those already established. Should the record be inserted and a new linked list established? Or should the record be rejected? Who should make that decision?